

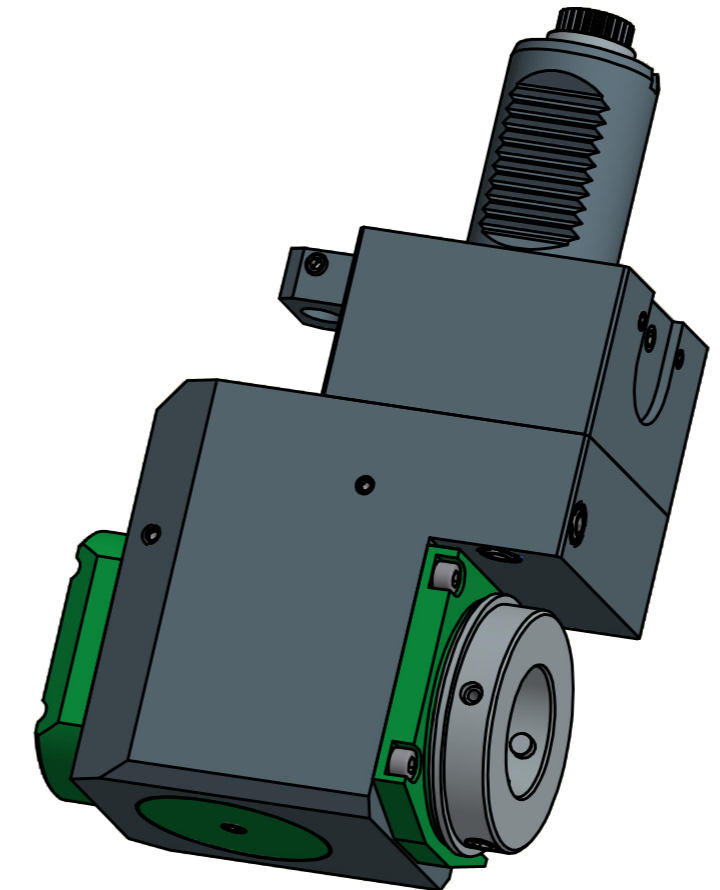
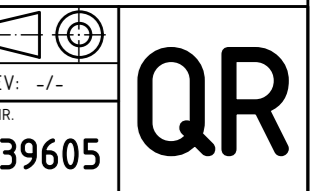

Doppelverzahnung Lizenz Traub
double tooth system licence Traub



Copyright **EWS Tool Technologies**
Weitergabe und Vervielfältigung dieser Unterlage,
Verwertung und Mitteilung ihres Inhalts nicht
gestattet, soweit nicht ausdrücklich zugestanden.
Zuwerhandlungen verpflichten zu Schadenersatz.

Bemerkung - Note Schutzrecht angemeldet Trademark right applied	Technische Daten - technical data Weight = 8.157 [kg] Torque max. (M1/M2) = 50 / 50 [Nm] Speed max. (n1/n2) = 6000 / 6000 [1/min] Gear ratio (i)=n1:n2 = 1:1	Benennung - Title Radial Bohr und Fräskopf, zurückges Radial drill. and mill. head offset	 EWS Weigle GmbH & Co. KG Maybachstr. 1 D-73066 Uhingen www.ews-tools.de Nr. - No. 80.40V4LCTXRL	Technische Änderungen vorbehalten! Subject to technical modifications! IDENT: D-EWS-072608 MNR. 139605	
---	--	---	--	---	---