

Spannzange / collet ER40 DIN6499  
 Spannbereich / clamping range: 3,0 - 26,0

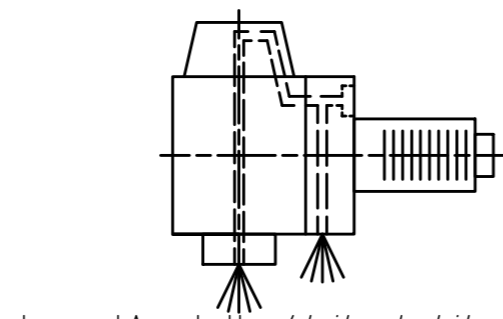

Innen- und Aussenkuehlung / Inside and outside coolant supply  
 Kuehlmittelfiltrierung=50µ / coolant filtration=50µ

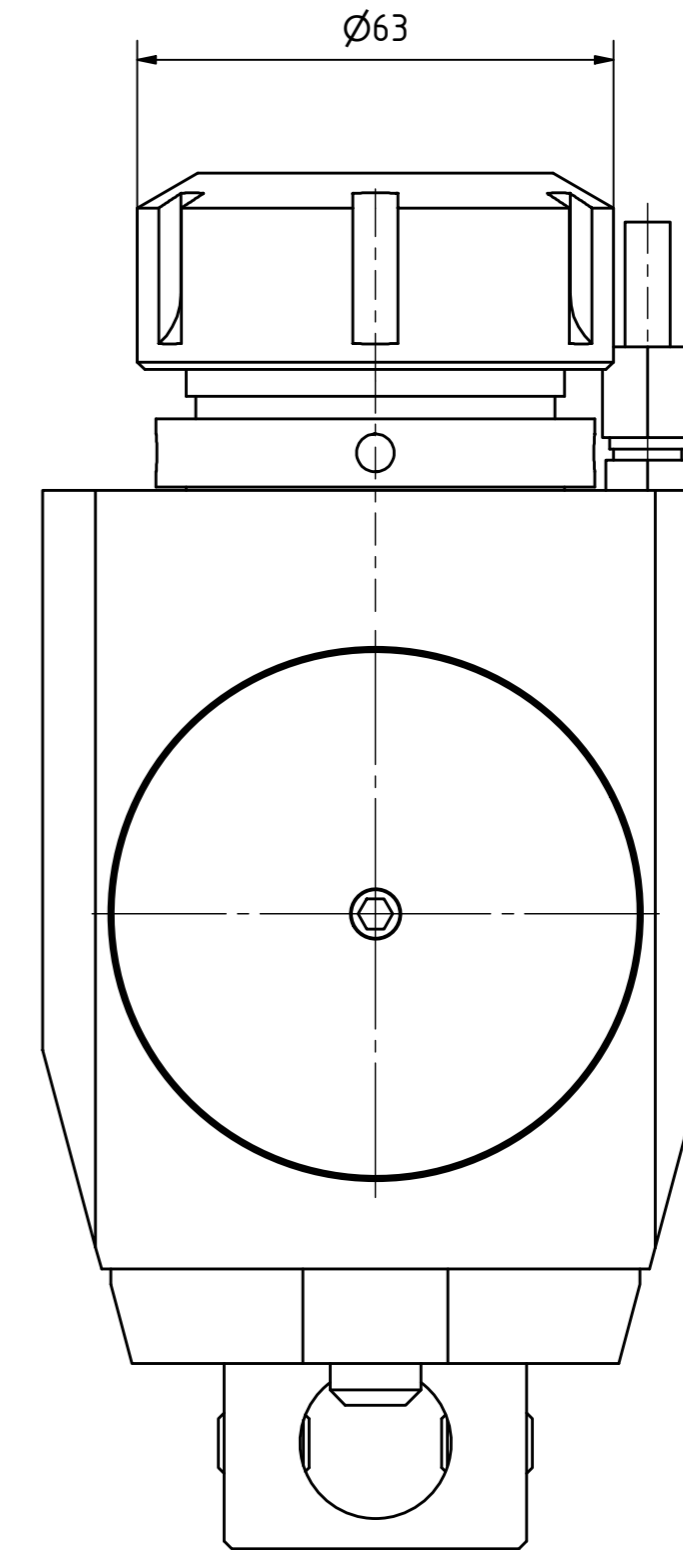
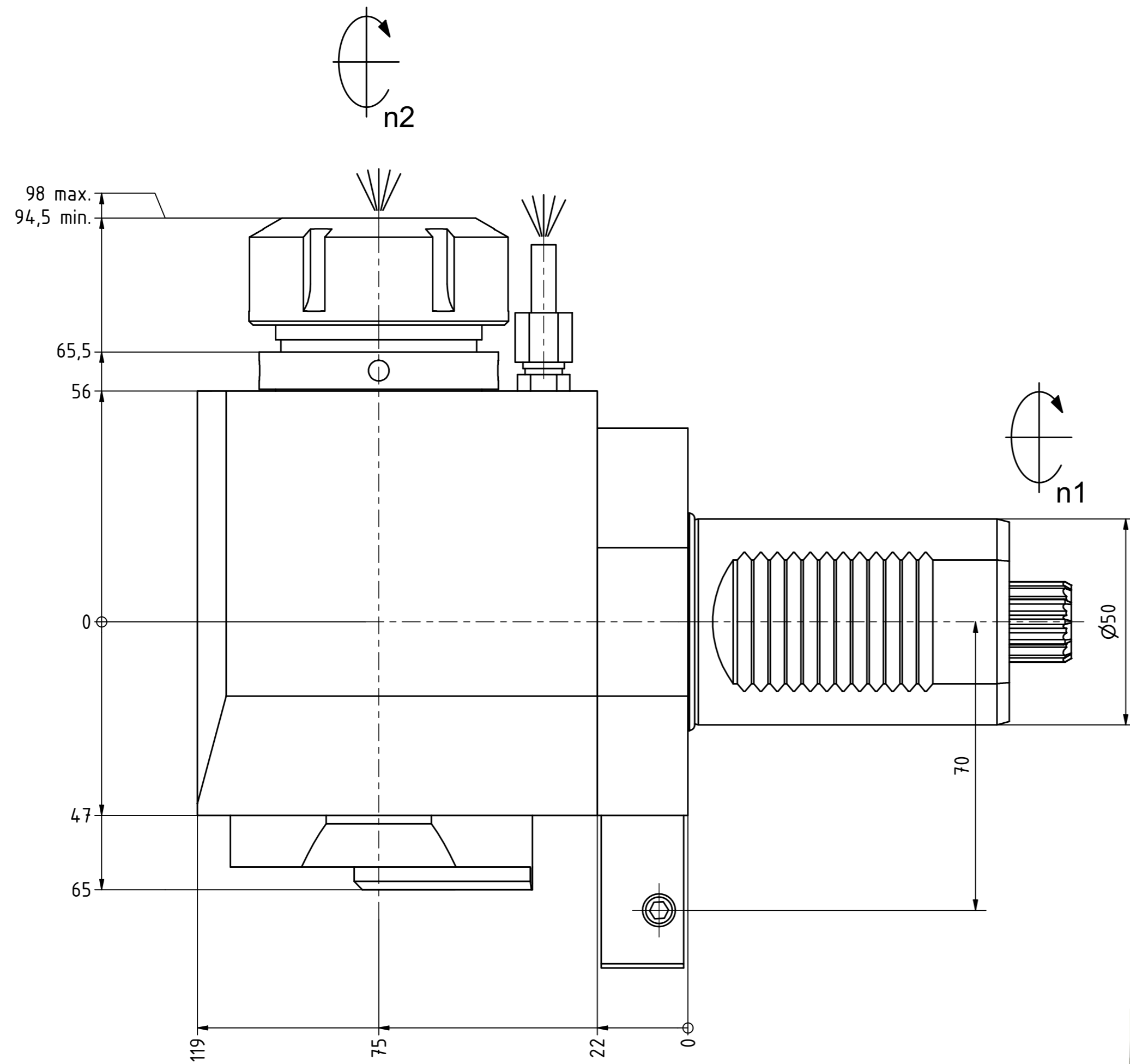
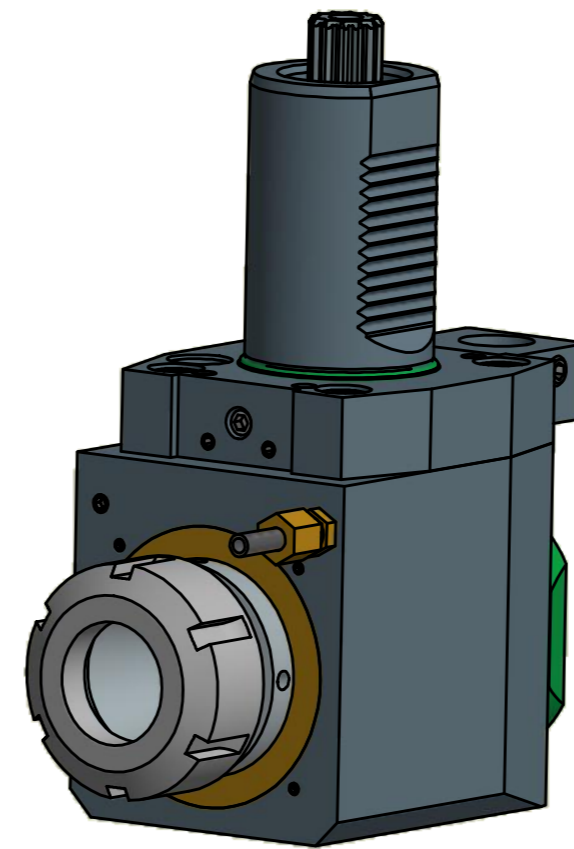

  
 Hakenschlüssel  
 mit Zapfen  
 Hook wrench  
 with fixed pin  
 DIN1810 B 58x62

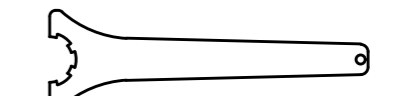
  
 Spannzangenschlüssel  
 Clamping wrench  
 240

Bemerkung - Note  
 Für Trockenlauf geeignet!  
 Use without coolant fluid allowed!

Technische Daten - technical data  
 Weight = 8.309 [kg]  
 Torque max. (M1/M2) = 100 / 100 [Nm]  
 Speed max. (n1/n2) = 4000 / 4000 [1/min]  
 Gear ratio (i)=n1:n2 = 1:1  
 Pressure (pmax) = 70 [bar]

Benennung - Title  
 Radial Bohr und Fräskopf  
 Radial drilling and milling head

**EWS** EWS Weigle GmbH & Co. KG  
 Maybachstr. 1  
 D-73066 Uhlingen  
 www.ews-tools.de  
 Technische Änderungen vorbehalten!  
 Subject to technical modifications!  
 IDENT: D-EWS-002605  
 Nr. - No. MNR. REV: -/-  
 60.504.05482LIKDGL 108075

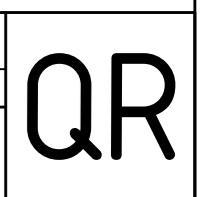

Copyright EWS Tool Technologies  
 Weitergabe und Vervielfaeltigung dieser Unterlage,  
 Verwertung und Mitteilung ihres Inhalts nicht  
 gestattet, soweit nicht ausdrecklich zugestanden.  
 Zuwiderhandlungen verpflichten zu Schadenersatz.