

Spannzange / collet ER32 DIN6499  
 Spannbereich / clamping range: 2,0 - 20,0

Gewindebohrzange / tapping collet  
 ET-1-32 M5-M12

Spannzangenschlüssel für  
 innenliegende Mutter  
 Clamping wrench for  
 internal collet  
 232AX

Hakenschlüssel  
 mit Nase  
 Hook wrench with  
 nose end  
 DIN1810 A 68x75

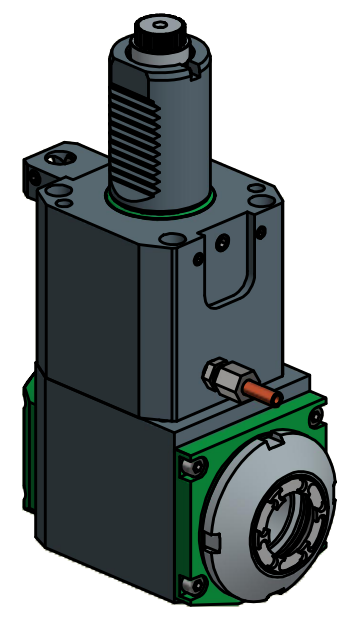

Copyright **EWS Tool Technologies**  
 Weitergabe und Vervielfältigung dieser Unterlage,  
 Verwertung und Mitteilung ihres Inhalts nicht  
 gestattet, soweit nicht ausdrücklich zugestanden.  
 Zuwiderhandlungen verpflichten zu Schadenersatz.

<p>Bemerkung - Note</p>	<p>Technische Daten - technical data</p> <p>Weight = 7.546 [kg]          Torque max. (M1/M2) = 50 / 50 [Nm]          Speed max. (n1/n2) = 6000 / 6000 [1/min]          Gear ratio (i)=n1:n2 = 1:1</p>	<p>Benennung - Title</p> <p><b>Radial Bohr und Fräskopf</b>  <b>Radial drilling and milling head</b></p>	<p><b>EWS</b> Tool Technologies  <small>EWS Weigle GmbH &amp; Co. KG          Maybachstr. 1          D-73066 UHINGEN          www.ews-tools.de</small></p> <p>Nr. - No.  <b>60.4032LCTXRIM</b></p>	<p>Technische Änderungen vorbehalten!          Subject to technical modifications!</p> <p>IDENT: D-EWS-051739</p>	<p></p> <p>REV: -/-</p> <p>MNR.  <b>139321</b></p>	<p><b>QR</b></p>
-------------------------	---	--	--	---	--	------------------