

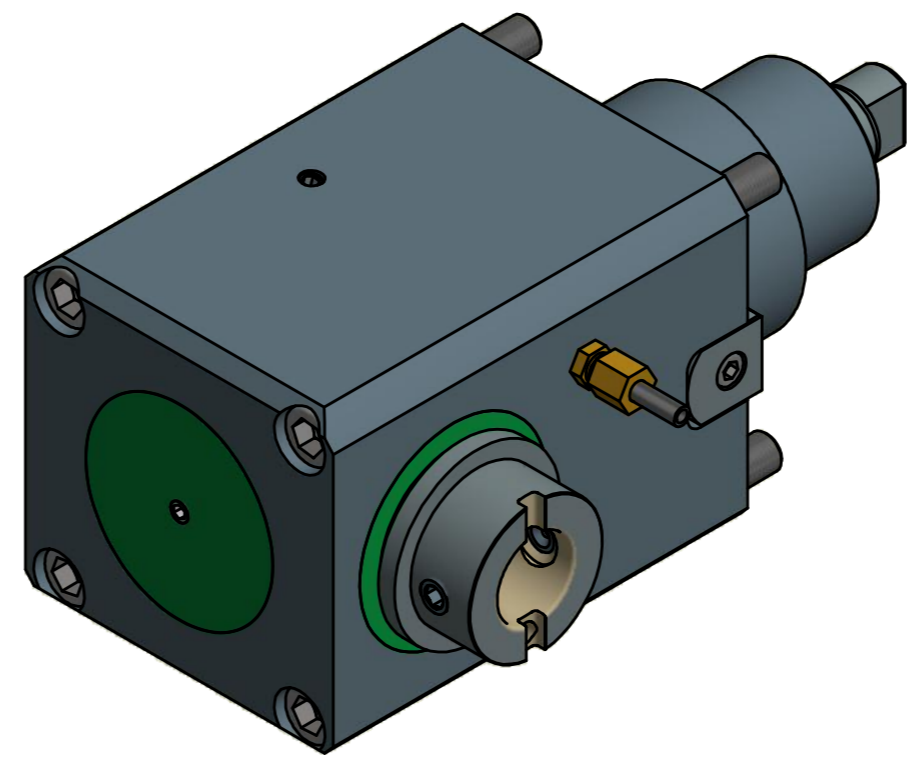
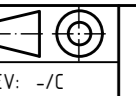

ABS 50  
(Lizenz Komet)



Copyright **EWS Tool Technologies**  
Weitergabe und Vervielfältigung dieser Unterlage,  
Verwertung und Mitteilung ihres Inhalts nicht  
gestattet, soweit nicht ausdrücklich zugestanden.  
Zuwerhandlungen verpflichten zu Schadenersatz.

Bemerkung - Note	Technische Daten - technical data <b>Weight</b> = 15.905 [kg] <b>Torque max.</b> (M1/M2) = 80 / 80 [Nm] <b>Speed max.</b> (n1/n2) = 4000 / 4000 [1/min] <b>Gear ratio</b> (i)=n1:n2 = 1:1	Benennung - Title <b>Radial Bohr und Fräskopf</b> <i>Radial drilling and milling head</i>	 <b>EWS</b> Weigle GmbH & Co. KG Maybachstr. 1 D-73066 Uhingen www.ews-tool.de	Technische Änderungen vorbehalten! <i>Subject to technical modifications!</i> IDENT: DEWS043308 REV: -/C MNR.	 <b>QR</b> 60.75ABS501809GLX110 139263
------------------	---	---	--	---	---