

Spannzange / collet ER32 DIN6499
Spannbereich / clamping range: 2,0 - 20,0

Gewindebohrzange / tapping collet
ET-1-32 M5-M12

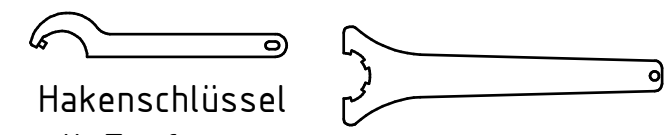
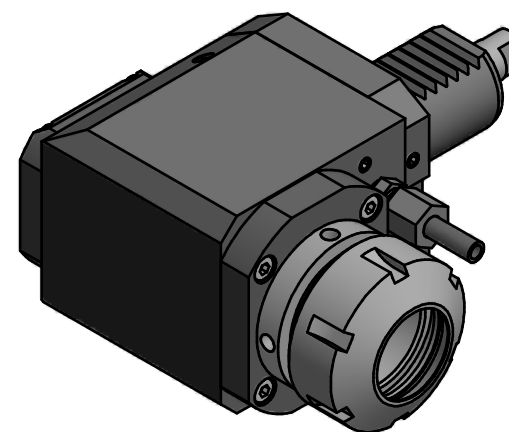

Hakenschlüssel mit Zapfen
Hook wrench with fixed pin
Spannzangenschlüssel
Clamping wrench
DIN1810 B 45x50 232

Copyright **EWS Tool Technologies**
Weitergabe und Vervielfaeltigung dieser Unterlage, Verwertung und Mitteilung ihres Inhalts nicht gestattet, soweit nicht ausdruerklich zugestanden. Zuwiderhandlungen verpflichten zu Schadenersatz.

Bemerkung - Note

Technische Daten - technical data	
Weight	= 3.007 [kg]
Torque max. (M1/M2)	= 25 / 25 [Nm]
Speed max. (n1/n2)	= 8000 / 8000 [1/min]
Gear ratio (i)=n1:n2	= 1:1

Benennung - Title	
Radial Bohr und Fräskopf	
<i>Radial drilling and milling head</i>	

EWS Tool Technologies	EWS Weigele GmbH & Co. KG Maybachstr. 1 D-73066 Uhingen www.ews-tools.de
	Nr. - No. 60.30321809R

Technische Aenderungen vorbehalten! Subject to technical modifications!
IDENT: D-EWS-000325

REV: B/-
MNR. 108579

