

6 | 5 | 4 | 3 | 2 | 1

D
C
B
A

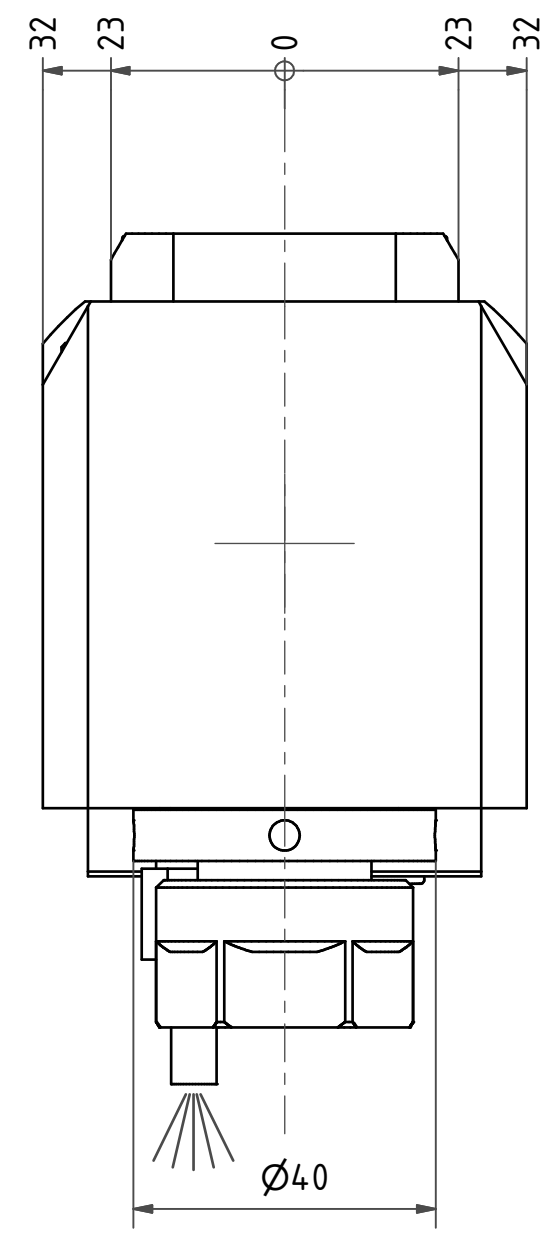

Spannzange / collet ER20 DIN6499
 Spannbereich / clamping range: 1,0 - 13,0
 Gewindebohrzange / tapping collet
 ET-1-20 M2-M6

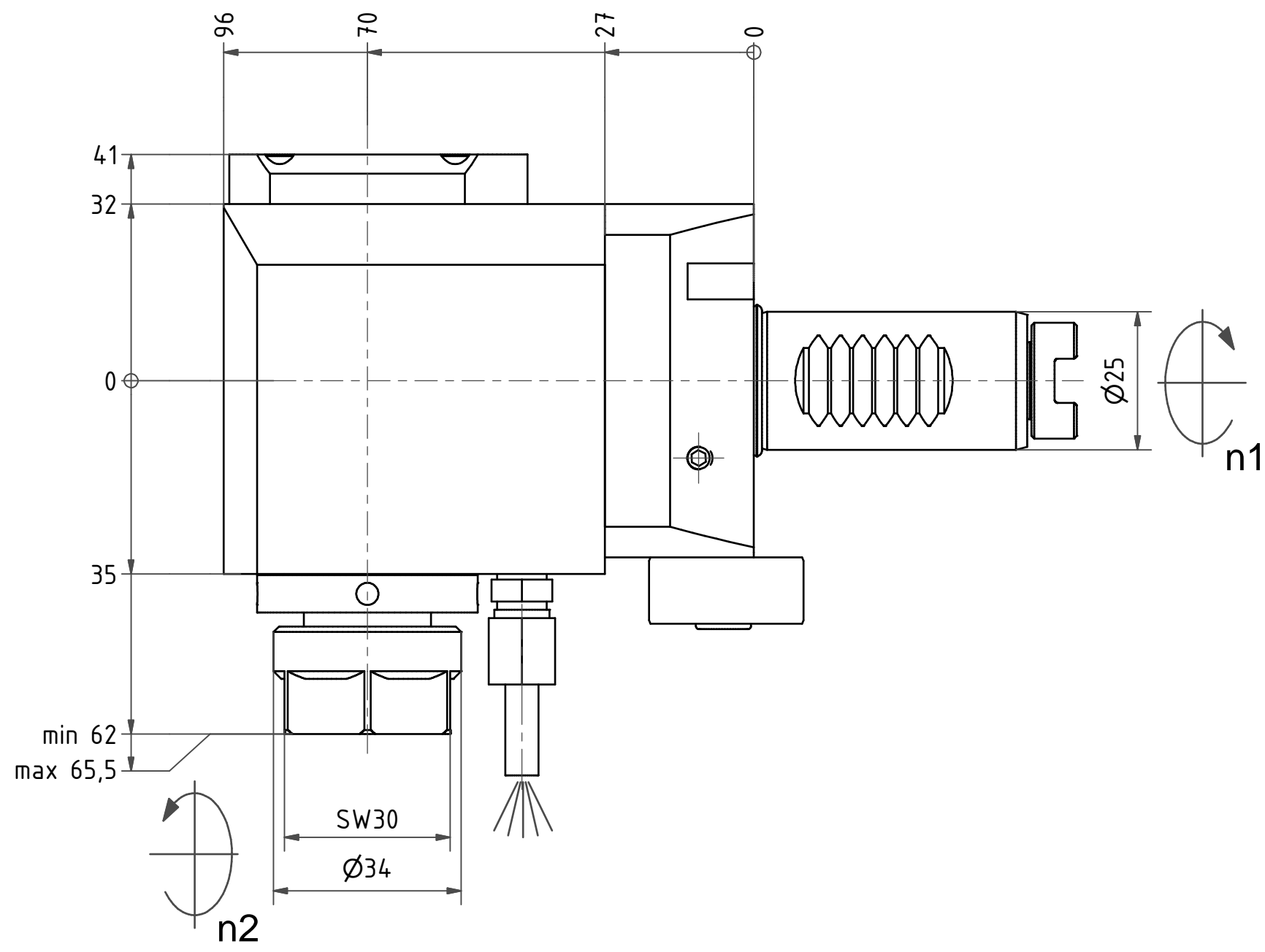
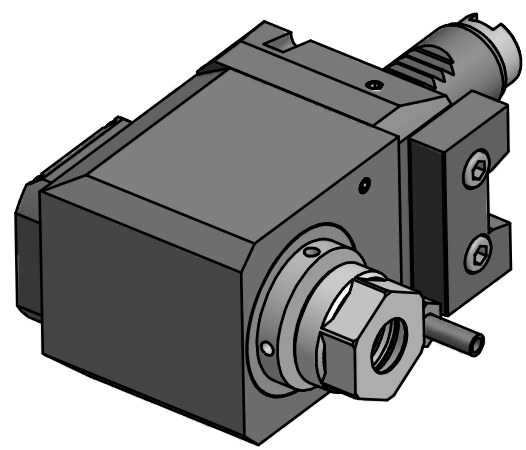
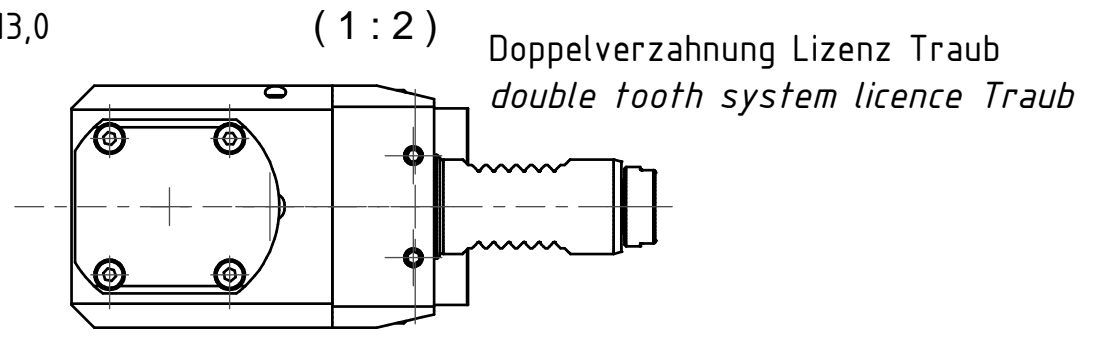

Hakenschlüssel
 mit Zapfen
 Hook wrench
 with fixed pin
 DIN1810 B 40x42

Copyright **EWS Tool Technologies**
 Weitergabe und Vervielfältigung dieser Unterlage,
 Verwertung und Mitteilung ihres Inhalts nicht
 gestattet, soweit nicht ausdrücklich zugestanden.
 Zuwiderhandlungen verpflichten zu Schadenersatz.

Bemerkung - Note	Technische Daten - technical data M1 / M2 = 25 / 25 Nm n1 / n2 = 8000 / 8000 1/min i (N1:N2) = 1:1	Benennung - Title Radial Bohr und Fräskopf <i>Radial drilling and milling head</i>	<table border="1"> <tr> <th>name</th> <th>date</th> </tr> <tr> <td>Kratschmann</td> <td>01.03.2007</td> </tr> </table>  EWS Weigete GmbH & Co. KG Maybachstr. 1 D-73066 Uhingen Tel. +49(0)7161/93040-100	name	date	Kratschmann	01.03.2007	Technische Aenderungen vorbehalten! Subject to technical modifications! Nr. 60.2520G200RLV MNR: 108558 IDENT: D-EWS-007447 A Blatt - page 1 (1)
name	date							
Kratschmann	01.03.2007							

6 | 5 | 4 | 3 | 2 | 1