

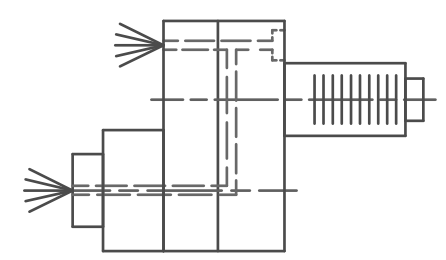

Spannzange / collet ER32 DIN6499  
 Spannbereich / clamping range: 2,0 - 20,0



Innen- und Aussenkuehlung / Inside and outside coolant supply  
 Kein Trockenlauf / No dry run  
 Kuehlmittelfiltrierung <math>< 50\mu</math> / coolant filtration <math>< 50\mu</math>

  
 Hakenschlüssel  
 mit Zapfen  
 Hook wrench  
 with fixed pin  
 DIN1810 B 45x50

  
 Spannzangenschlüssel  
 Clamping wrench  
 232

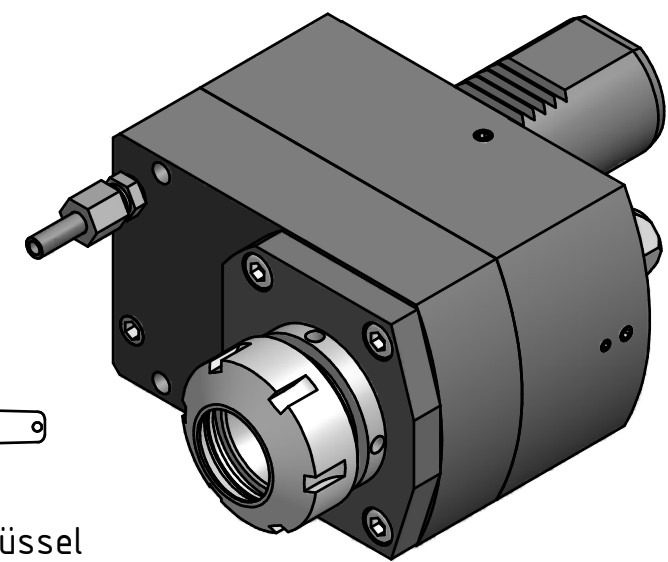

Copyright **EWS Tool Technologies**  
 Weitergabe und Vervielfaeltigung dieser Unterlage,  
 Verwertung und Mitteilung ihres Inhalts nicht  
 gestattet, soweit nicht ausdrecklich zugestanden.  
 Zuwiderhandlungen verpflichten zu Schadenersatz.

<p>Bemerkung - Note          Nicht ohne Kuehlmittel betreiben!          Not for use without coolant-fluid!</p>	<p>Technische Daten - technical data          M1 / M2 = 50 / 50 Nm          n1 / n2 = 6000 / 6000 1/min          i (N1:N2) = 1:1          pmax = 70 bar</p>	<p>Benennung - Title  <b>Axial Bohr u. Fräskopf achsversetzt</b>  <b>Ax. drill. and mill. head offset</b></p>	<table border="1"> <tr> <th>name</th> <th>date</th> </tr> <tr> <td>drawing</td> <td>16.03.2007</td> </tr> </table> <p><b>EWS</b> EWS Weigele GmbH &amp; Co. KG          Maybachstr. 1          D-73066 Uhingen          Tel. +49(0)7161/93040-100</p>	name	date	drawing	16.03.2007	<p>Technische Aenderungen vorbehalten!          Subject to technical modifications!</p> <p>Nr.  <b>50.4032MP620RIK</b></p> <p>DIN A3</p> <p>MNR: 108704 IDENT: D-EWS-012411 A Blatt - page 1 (1)</p>
name	date							
drawing	16.03.2007							