

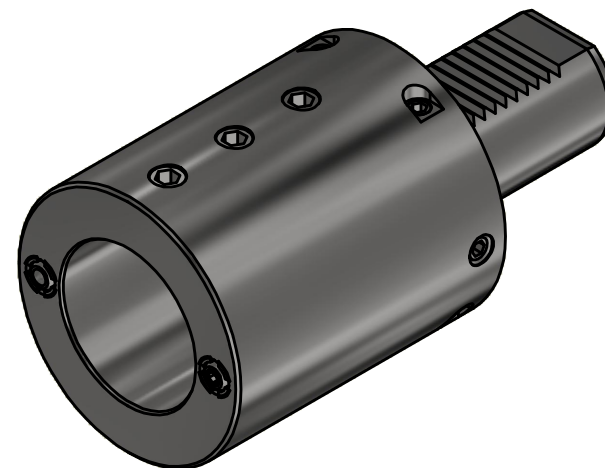

Achtung: Darf nur mit Verschlussstopfen verwendet werden!  
 Attention: May only be used with sealing plug!

Anzugsmoment: 40 Nm  
 Tightening torque: 40 Nm

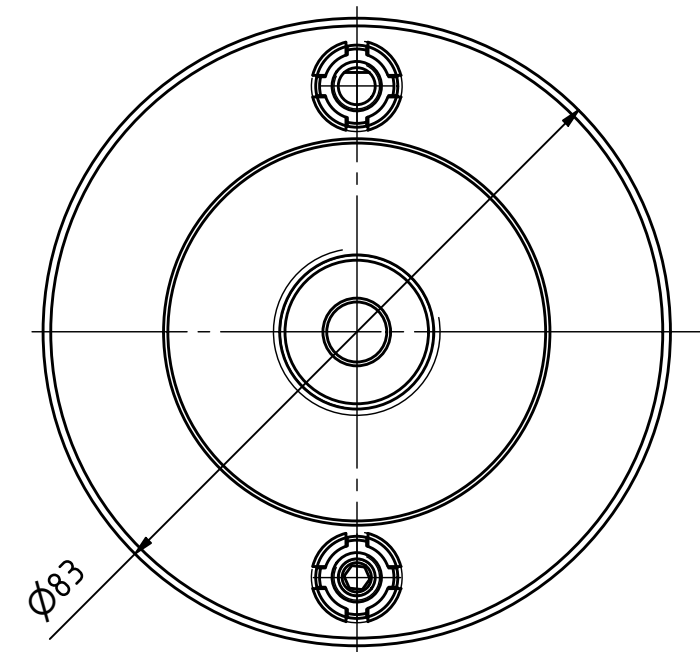

Copyright **EWS Tool Technologies**  
 Weitergabe und Vervielfaeltigung dieser Unterlage,  
 Verwertung und Mitteilung ihres Inhalts nicht  
 gestattet, soweit nicht ausdrecklich zugestanden.  
 Zuwiderhandlungen verpflichten zu Schadenersatz.

Bemerkung - Note	Technische Daten - technical data Weight = 3.257 [kg]	Benennung - Title <b>Bohrstangenhalter</b> <i>Boring bar holder</i>	 <b>EWS</b> <small>Tool Technologies</small> <small>EWS Weigele GmbH &amp; Co. KG          Maybachstr. 1          D-73066 Uhingen          www.ews-tools.de</small>	Technische Aenderungen vorbehalten! Subject to technical modifications! IDENT: DEWS132497	 REV: -/B MNR. <b>137497</b>	
------------------	--	---	--	---	--	---