

Schwenkbereich  $\pm 105^\circ$   
Swivel area  $\pm 105^\circ$

Spannzange / collet ER25 DIN6499  
Spannbereich / clamping range: 1,0 - 16,0

Gewindebohrzange / tapping collet  
ET-1-25 M3-M10

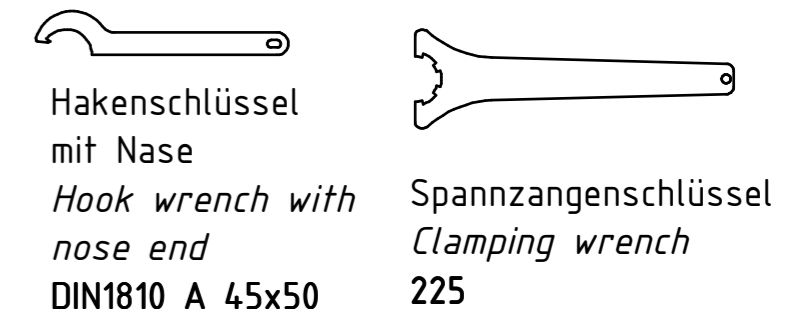
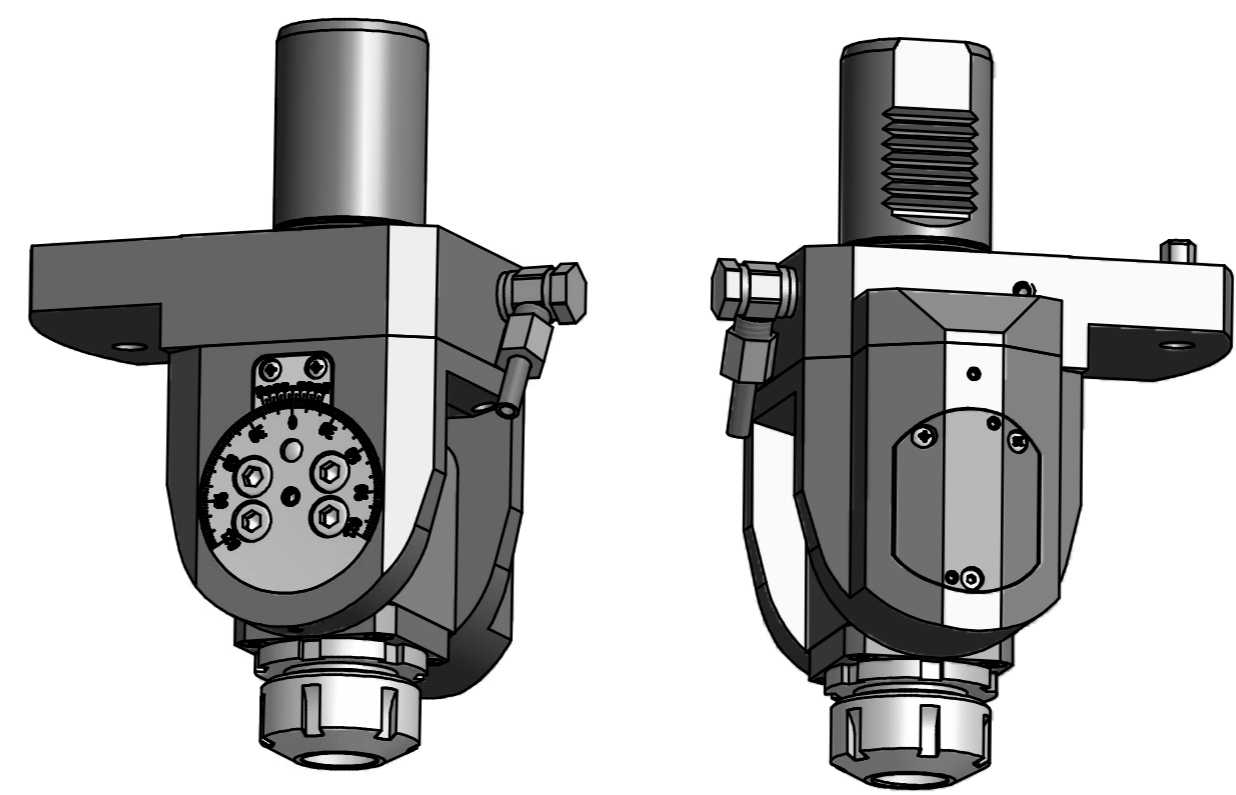

Hakenschlüssel  
mit Nase  
Hook wrench with  
nose end  
DIN1810 A 45x50

Spannzangenschlüssel  
Clamping wrench  
225

Copyright **EWS Tool Technologies**  
Weitergabe und Vervielfältigung dieser Unterlage,  
Verwertung und Mitteilung ihres Inhalts nicht  
gestattet, soweit nicht ausdrücklich zugestanden.  
Zuwendungen verpflichten zu Schadenersatz.

Bemerkung - Note	Technische Daten - Technical data	Benennung - Title	name Theiss date 16.09.2011 Technische Änderungen vorbehalten! Subject to technical modifications! Nr. <b>63.4025KMP610</b> MNR: 100846 IDENT: D-EWS-109232 - Blatt - page 1 (1)
	M <sub>1</sub> / M <sub>2</sub> = 20 / 20 Nm n <sub>1</sub> / n <sub>2</sub> = 6000 / 6000 1/min i (N <sub>1</sub> :N <sub>2</sub> ) = 1:1		

