

Schwenkbereich $\pm 105^\circ$
swivel area $\pm 105^\circ$

Spannzange / Collet ER16 DIN6499
Spannbereich / Clamping range: 1,0 - 10,0

Gewindebohrzange / Tapping Collet
ET-1-16 M1-M6

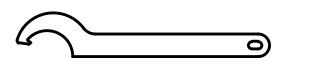
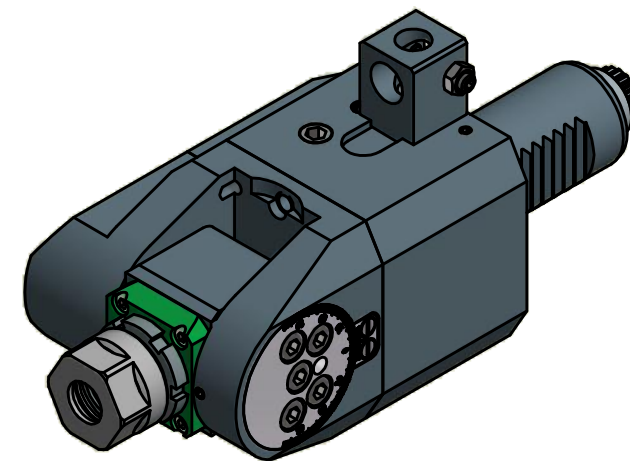
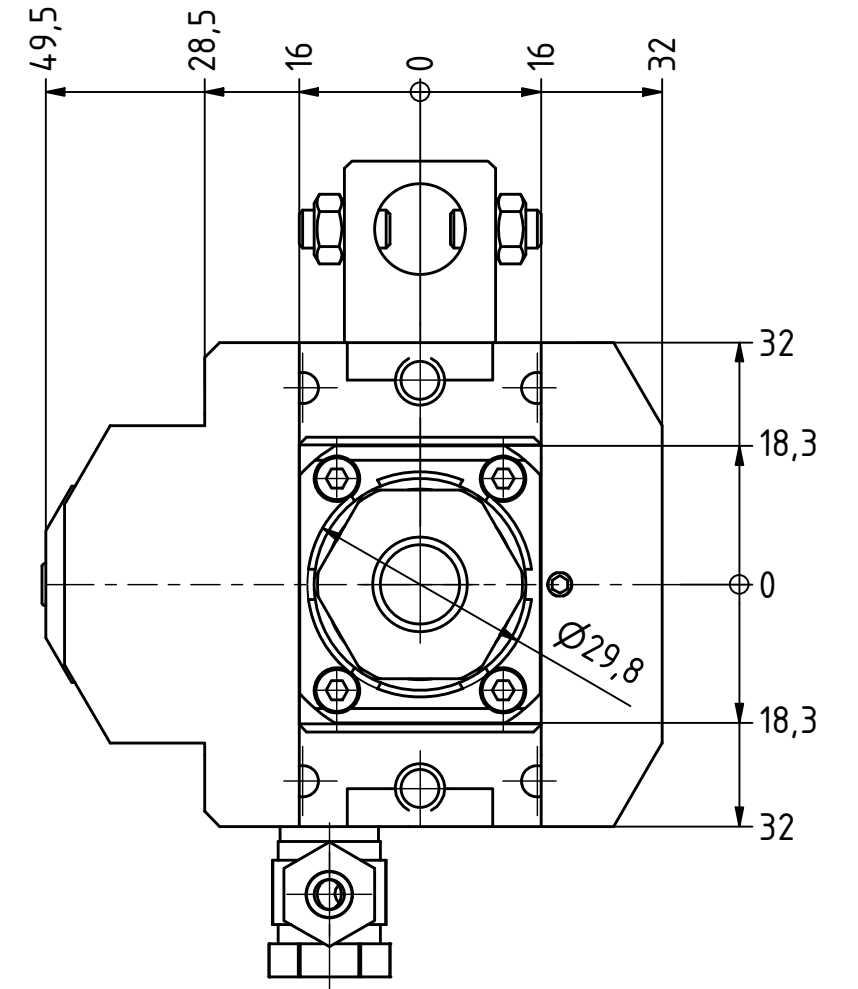
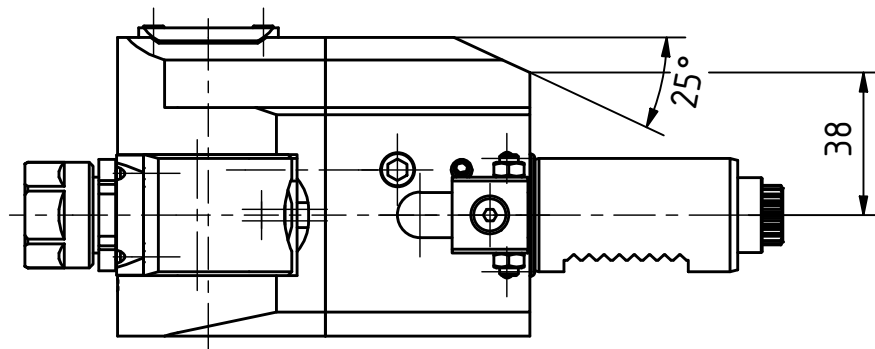

Hakenschlüssel
mit Nase
Hook wrench with
nose end
DIN1810 A 30x32

Beide Nachbarstationen könnten entfallen!
both neighbouring stations may be lost!

Copyright **EWS Tool Technologies**
Weitergabe und Vervielfältigung dieser Unterlage,
Verwertung und Mitteilung ihres Inhalts nicht
gestattet, soweit nicht ausdrücklich zugestanden.
Zu widerhandlungen verpflichten zu Schadenersatz.

Bemerkung - Note	Technische Daten - technical data Weight = 3.431 [kg] Torque max. (M1/M2) = 16 / 8 [Nm] Speed max. (n1/n2) = 6000 / 12000 [1/min] Gear ratio (i)=n1:n2 = 1:2	Benennung - Title Schwenkkopf Swivel head	 EWS Weigele GmbH & Co. KG Maybachstr. 1 D-73066 UHINGEN www.ews-tools.de Nr. - No. 63.3016GT3001	Technische Änderungen vorbehalten! Subject to technical modifications! IDENT: DEWS089936 MNR. 100834	 REV: -/A 
------------------	--	---	---	--	--