

Spannzange / Collet ER16 DIN6499
 Spannungsbereich / Clamping range: 1,0 - 10,0

Gewindebohrzange / Tapping Collet
 ET-1-16 M1-M6

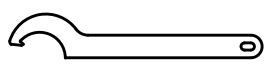

Hakenschlüssel
 mit Nase
 Hook wrench with
 nose end
 DIN1810 A 30x32

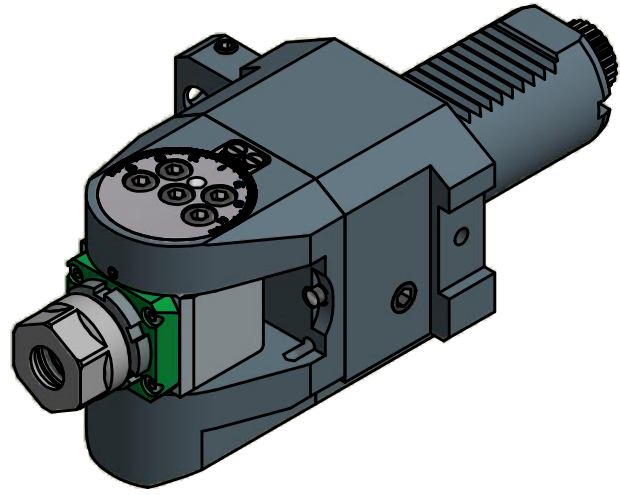

Copyright **EWS Tool Technologies**
 Weitergabe und Vervielfaeltigung dieser Unterlage,
 Verwertung und Mitteilung ihres Inhalts nicht
 gestattet, soweit nicht ausdrecklich zugestanden.
 Zuwiderhandlungen verpflichten zu Schadenersatz.

Bemerkung - Note	Technische Daten - technical data Weight = 3.644 [kg] Torque max. (M1/M2) = 32 / 16 [Nm] Speed max. (n1/n2) = 6000 / 12000 [1/min] Gear ratio (i)=n1:n2 = 1:2	Benennung - Title Schwenkkopf Swivel head	 EWS Weigele GmbH & Co. KG Maybachstr. 1 D-73066 UHINGEN www.ews-tools.de Nr. - No. 63.4016CTXI1	Technische Aenderungen vorbehalten! Subject to technical modifications! IDENT: D-EWS-005125 MNR. 100841	 QR
------------------	---	---	--	---	--------