

6 5 4 3 2 1

D

C

B

A

D

C

B

A

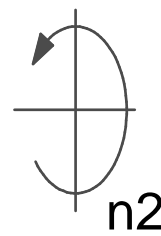
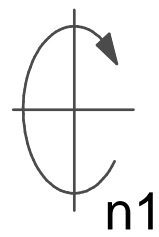
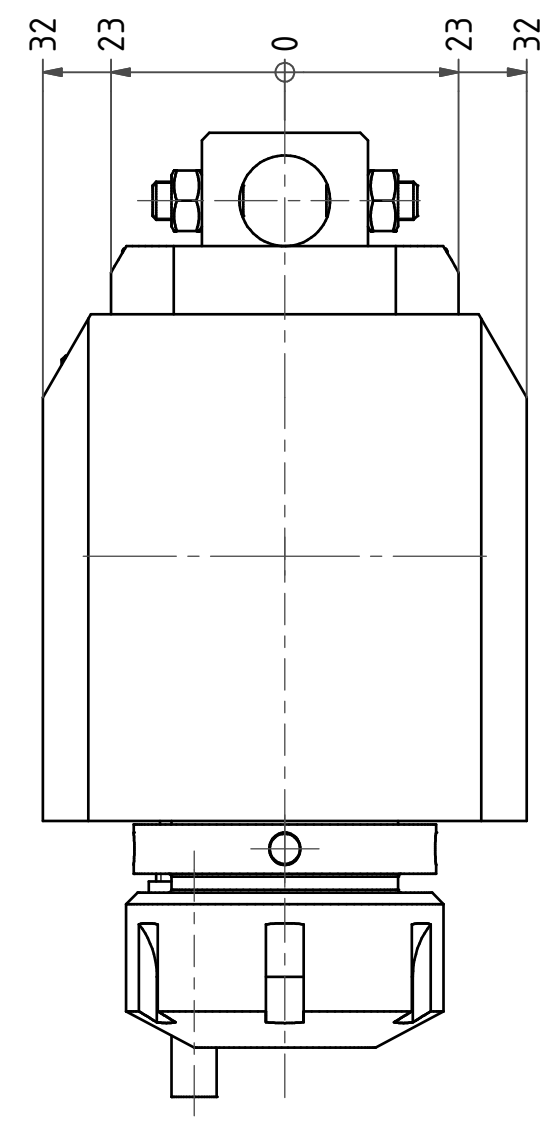
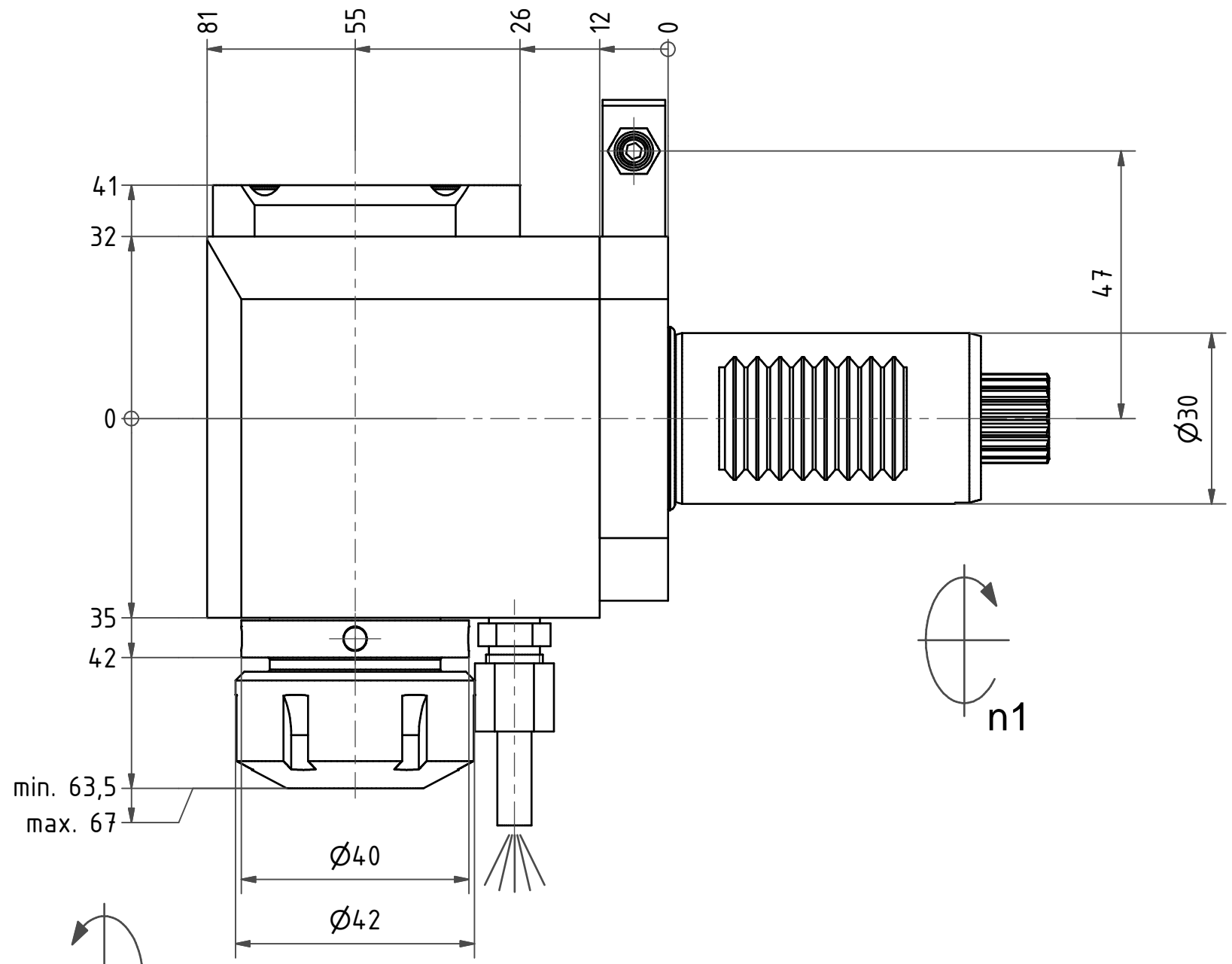

Spannzange / collet ER25 DIN6499
Spannbereich / clamping range: 1,0 - 16,0

Gewindebohrzange / tapping collet
ET-1-25 M3-M10

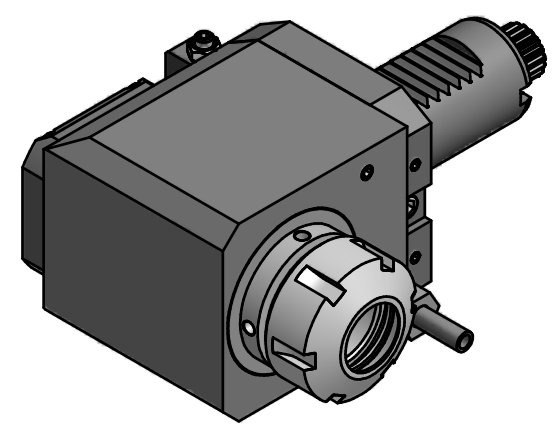

Hakenschlüssel
mit Zapfen
Hook wrench
with fixed pin
DIN1810 B 40x42

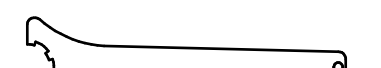

Spannzangenschlüssel
Clamping wrench
225

Copyright **EWS Tool Technologies**
Weitergabe und Vervielfältigung dieser Unterlage,
Verwertung und Mitteilung ihres Inhalts nicht
gestattet, soweit nicht ausdrücklich zugestanden.
Zu widerhandlungen verpflichten zu Schadenersatz.

<p>Bemerkung - Note</p>	<p>Technische Daten - technical data M1 / M2 = 25 / 25 Nm n1 / n2 = 8000 / 8000 1/min i (N1:N2) = 1:1</p>	<p>Benennung - Title Radial Bohr und Fräskopf <i>Radial drilling and milling head</i></p>	<table border="1"> <tr> <td>name</td> <td>date</td> </tr> <tr> <td>Kratschmann</td> <td>09.03.2007</td> </tr> </table>	name	date	Kratschmann	09.03.2007	<p>Technische Änderungen vorbehalten! Subject to technical modifications!</p> <p>Nr. 60.3025MFSR</p>	 DIN A3 MNR: 100741 IDENT: D-EWS-009566 A Blatt - page 1 (1)
name	date								
Kratschmann	09.03.2007								

6 5 4 3 2 1