

max. 74  
min. 70,5

Ø42

Spannzange / *collet* ER25 DIN6499  
Spannbereich / *clamping range*: 1,0 - 16,0

Gewindebohrzange / *tapping collet*  
ET-1-25 M3-M10

49

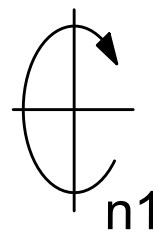

n1

0

Ø25

30

49

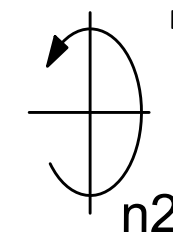

min. 70,5  
max. 74

Ø42

106

75

0

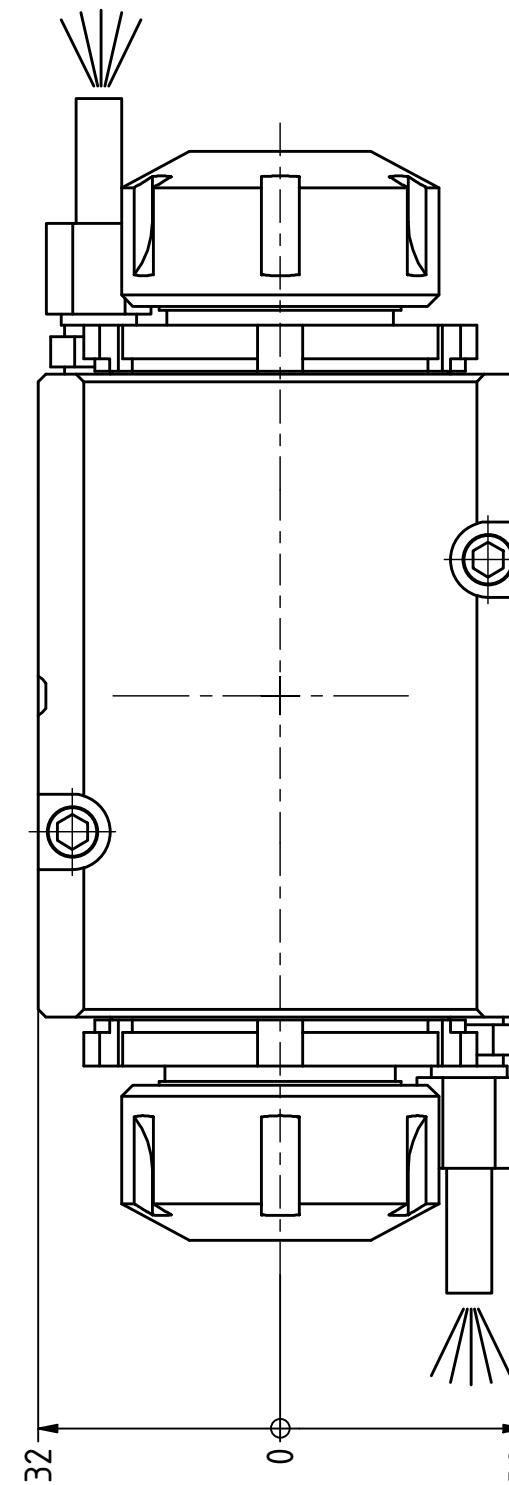

32

0

32

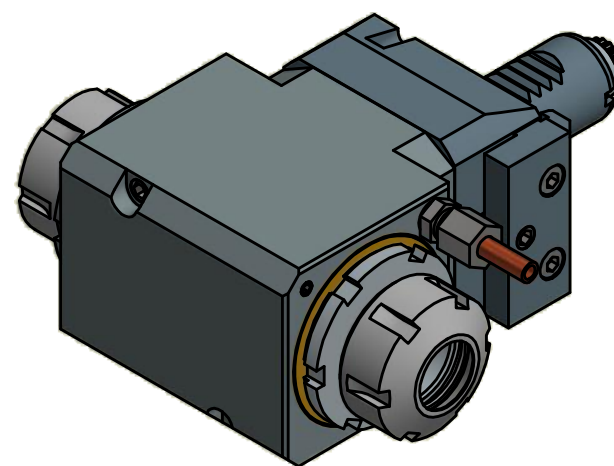
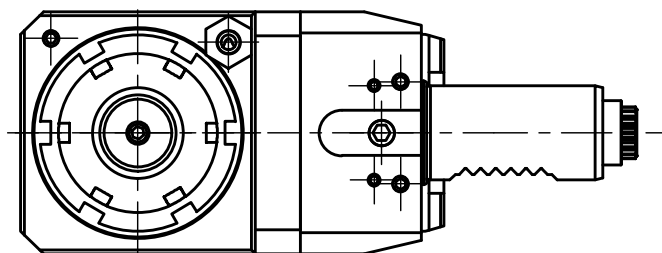

Copyright **EWS Tool Technologies**  
Weitergabe und Vervielfaeltigung dieser Unterlage,  
Verwertung und Mitteilung ihres Inhalts nicht  
gestattet, soweit nicht ausdrecklich zugestanden.  
Zuwoiderhandlungen verpflichten zu Schadenersatz.

Bemerkung - Note

Technische Daten - technical data

Weight = 3.970 [kg]  
Torque max. (M1/M2) = 25 / 25 | 25 [Nm]  
Speed max. (n1/n2) = 8000 / 8000 | 8000 [1/min]  
Gear ratio (i)=n1:n2 = 1:1 | 1:1

Benennung - Title

Radial Bohr und Fräskopf  
Radial drilling and milling head



EWS Weigele GmbH & Co. KG  
Maybachstr. 1  
D-73066 UHINGEN  
www.ews-tools.de

Technische Aenderungen vorbehalten!  
Subject to technical modifications!

IDENT: DEWS098248



REV: -/C

Nr. - No.

60.2525DE332

MNR.

100666

