

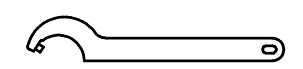

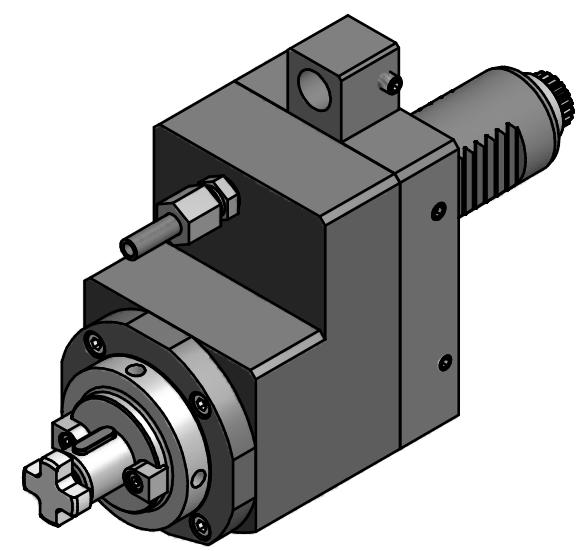

Doppelverzahnung Lizenz Traub
double tooth system licence Traub



Hakenschlüssel
mit Zapfen
Hook wrench
with fixed pin
DIN1810 B 45x50

Copyright **EWS Tool Technologies**
Weitergabe und Vervielfaeltigung dieser Unterlage,
Verwertung und Mitteilung ihres Inhalts nicht
gestattet, soweit nicht ausdruücklich zugestanden.
Zuwoiderhandlungen verpflichten zu Schadenersatz.

Bemerkung - Note 	Technische Daten - technical data Weight = 3.443 [kg] Torque max. (M1/M2) = 20 / 40 [Nm] Speed max. (n1/n2) = 6000 / 3000 [1/min] Gear ratio (i)=n1:n2 = 2:1	Benennung - Title Axial Fräskopf . achsversetzt Axial milling head offset	 EWS Weigele GmbH & Co. KG Maybachstr. 1 D-73066 Uhingen www.ews-tools.de Nr. - No. 52.3016CTXRLI2	Technische Aenderungen vorbehalten! Subject to technical modifications! IDENT: D-EWS-194019 MNR. 100622	 REV: -/- 
--------------------------	--	---	---	--	--