

Spannzange / collet ER25 DIN6499  
 Spannbereich / clamping range: 1,0 - 16,0

Gewindebohrzange / tapping collet  
 ET-1-25 M3-M10

 Spannzangenschlüssel  
 Clamping wrench  
 225

 Hakenschlüssel  
 mit Zapfen  
 Hook wrench  
 with fixed pin  
 DIN1810 B 45x50

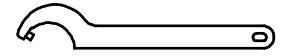
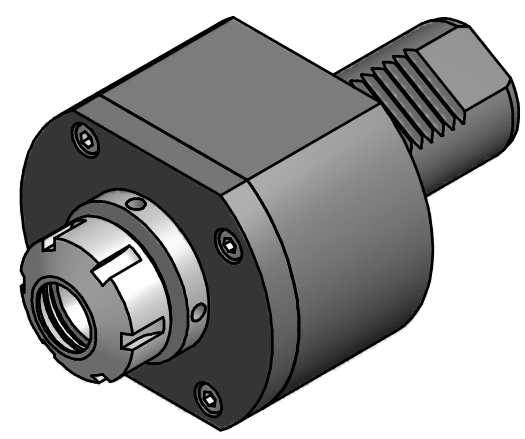

Copyright **EWS Tool Technologies**  
 Weitergabe und Vervielfältigung dieser Unterlage,  
 Verwertung und Mitteilung ihres Inhalts nicht  
 gestattet, soweit nicht ausdrücklich zugestanden.  
 Zuwiderhandlungen verpflichten zu Schadenersatz.

Bemerkung - Note	Technische Daten - technical data M1 / M2 = 50 / 50 Nm n1 / n2 = 6000 / 6000 1/min i (N1:N2) = 1:1	Benennung - Title <b>Axial Bohr und Fräskopf</b> <i>Axial drilling and milling head</i>	<table border="1"> <tr> <th>name</th> <th>date</th> </tr> <tr> <td>drawing</td> <td>15.03.2007</td> </tr> </table>	name	date	drawing	15.03.2007	Technische Aenderungen vorbehalten! Subject to technical modifications! Nr. <b>40.4025SQT10</b> MNR: 100567 IDENT: D-EWS-012858 - Blatt - page 1 (1)	 DIN A3
name	date								
drawing	15.03.2007								