

Spannzange / collet ER32 DIN6499
 Spannbereich / clamping range: 2,0 - 20,0

Gewindebohrzange / tapping collet
 ET-1-32 M5-M12

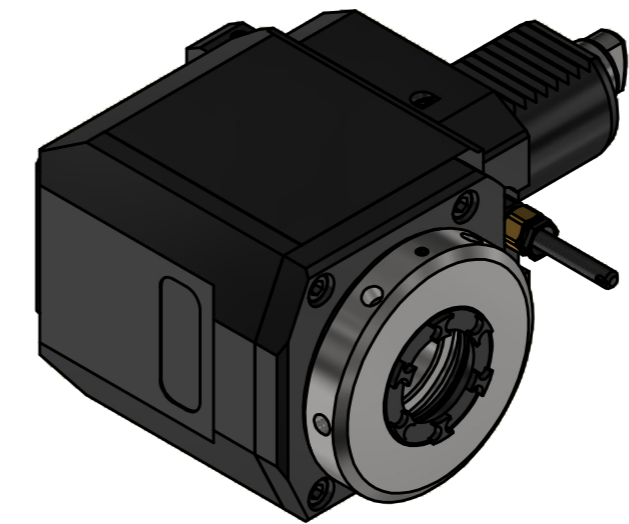

Hakenschlüssel mit Zapfen
 Hook wrench with fixed pin
 DIN1810 B 68x75

Spannzangenschlüssel für innenliegende Mutter
 Clamping wrench for internal collet
 232AX

Copyright **EWS Tool Technologies**
 Weitergabe und Vervielfältigung dieser Unterlage, Verwertung und Mitteilung ihres Inhalts nicht gestattet, soweit nicht ausdrücklich zugestanden. Zuwiderhandlungen verpflichten zu Schadenersatz.

Bemerkung - Note mit Kegelrollenlager with taper roller bearing(s)	Technische Daten - technical data Weight = 5,656 [kg] Torque max. (M1/M2) = 63 / 63 [Nm] Speed max. (n1/n2) = 5000 / 5000 [1/min] Gear ratio (i)=n1:n2 = 1:1	Benennung - Title Radial Bohr und Fräskopf Radial drilling and milling head	 EWS Weigle GmbH & Co. KG Maybachstr. 1 D-73066 Uhingen www.ews-tool.de Nr. - No. 60.4032KR1809RIM	Technische Änderungen vorbehalten! Subject to technical modifications! IDENT: DEWS269853 REV: -/A MNR. 233435	
--	--	---	---	---	--