

Spannzange / collet ER25 DIN6499  
Spannbereich / clamping range: 1,0 - 16,0

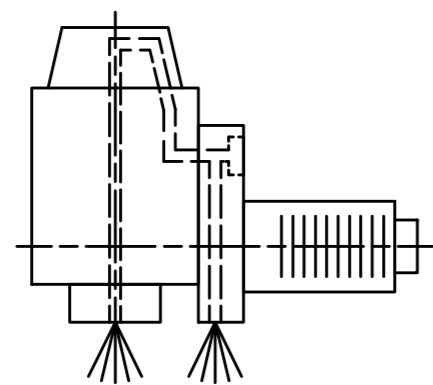

Innen- und Aussenkuehlung / Inside and outside coolant supply  
Kuehlmittelfiltrierung=50µ / coolant filtration=50µ

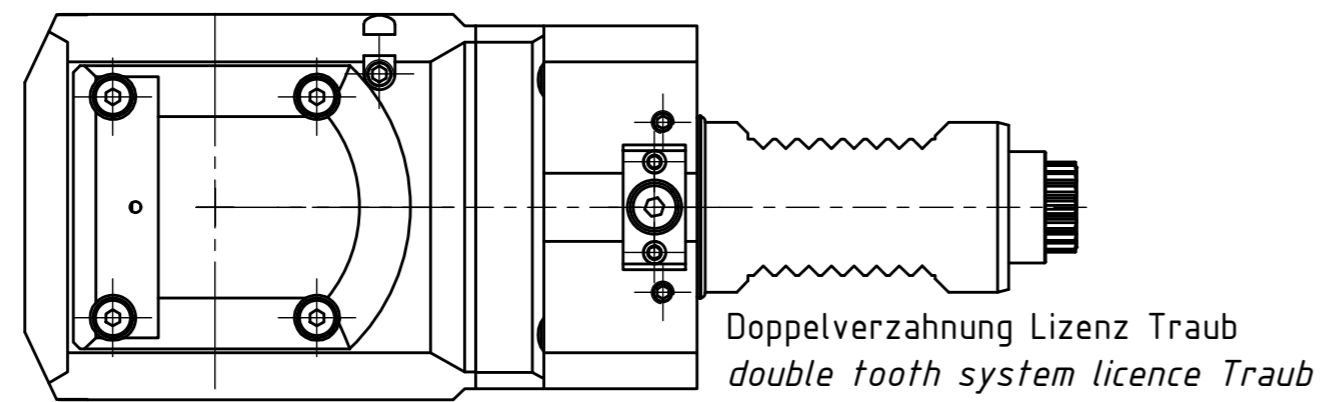
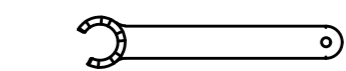
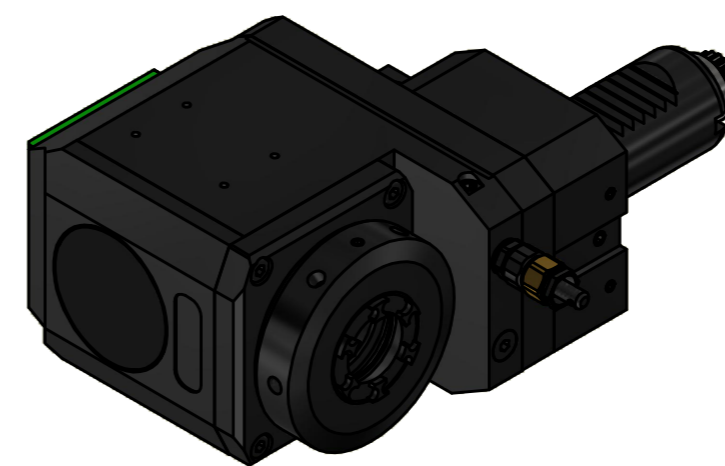

Spannzangenschlüssel für innenliegende Mutter  
Clamping wrench for internal collet  
225AX

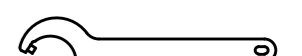

Hakenschlüssel mit Zapfen  
Hook wrench with fixed pin  
DIN1810 B 58x62

Copyright **EWS Tool Technologies**  
Weitergabe und Vervielfältigung dieser Unterlage, Verwertung und Mitteilung ihres Inhalts nicht gestattet, soweit nicht ausdrücklich zugestanden. Zuwiderhandlungen verpflichten zu Schadenersatz.

Bemerkung - Note  
Für Trockenlauf geeignet!  
Use without coolant fluid allowed!

Technische Daten - technical data  
Weight = 4,801 [kg]  
Torque max. (M1/M2) = 24 / 12 [Nm]  
Speed max. (n1/n2) = 6000 / 12000 [1/min]  
Gear ratio (i)=n1:n2 = 1:2  
Pressure (pmax) = 70 [bar]

Benennung - Title  
Radial Bohr und Fräskopf, zurückges  
Radial drill. and mill. head offset

	<small>EWS Weigle GmbH &amp; Co. KG Maybachstr. 1 D-73066 Uhlingen www.ews-tools.de</small>	<small>Technische Änderungen vorbehalten! Subject to technical modifications!</small>	
		<small>IDENT: DEWS269230</small>	
<small>Nr. - No.</small> 80.3025GT300RLIKD11M	<small>MNR.</small> 233367		