

Spannzange / collet ER32 DIN6499
Spannbereich / clamping range: 2,0 - 20,0

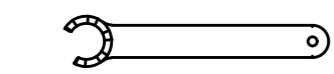

Spannzangenschlüssel für innenliegende Mutter
Clamping wrench for internal collet
232AX

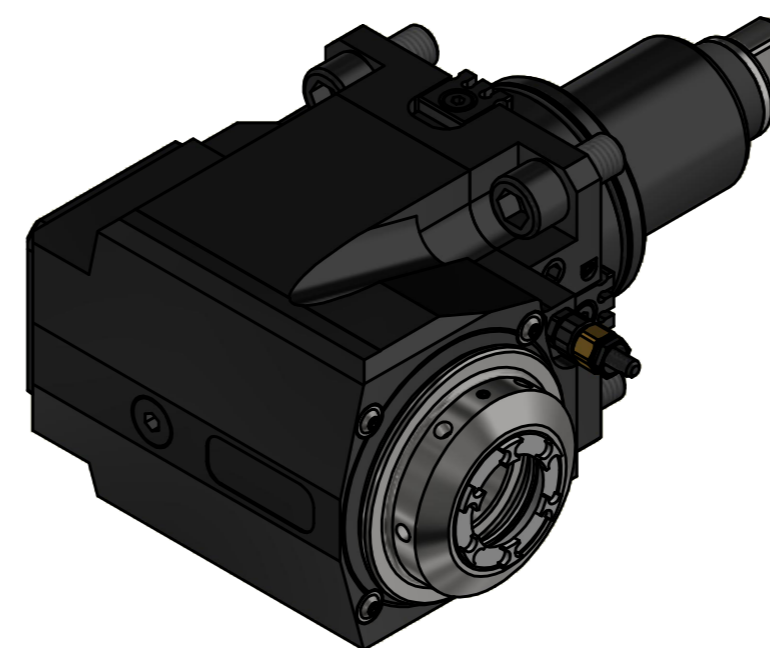
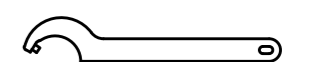

Hakenschlüssel mit Zapfen
Hook wrench with fixed pin
DIN1810 B 58x62

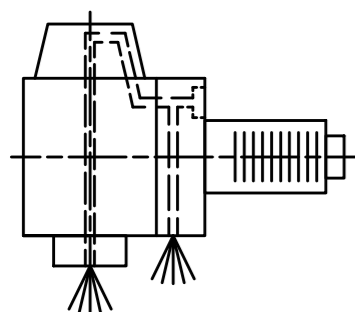

Innen- und Aussenkühlung / Inside and outside coolant supply
Kühlmittelfiltrierung-50µ / coolant filtration-50µ

Copyright **EWS Tool Technologies**
Weitergabe und Vervielfältigung dieser Unterlage, Verwertung und Mitteilung ihres Inhalts nicht gestattet, soweit nicht ausdrücklich zugestanden. Zuwiderhandlungen verpflichten zu Schadenersatz.

<p>Bemerkung - Note Für Trockenlauf geeignet! Use without coolant fluid allowed!</p>	<p>Technische Daten - technical data Weight = 10.550 [kg] Torque max. (M1/M2) = 80 / 80 [Nm] Speed max. (n1/n2) = 6000 / 6000 [1/min] Gear ratio (i)=n1:n2 = 1:1 Pressure (pmax) = 70 [bar]</p>	<p>Benennung - Title Radial Bohr und Fräskopf Radial drilling and milling head</p>	<p>EWS Tool Technologies EWS Weigle GmbH & Co. KG Maybachstr. 1 D-73066 Uhingen www.ews-tool.de Technische Änderungen vorbehalten! Subject to technical modifications! IDENT: DEWS268994 REV: -/A MNR. 233333</p>	<p>QR</p>
--	---	--	--	------------------