

Spannzange / collet ER32 DIN6499  
 Spannbereich / clamping range: 2,0 - 20,0

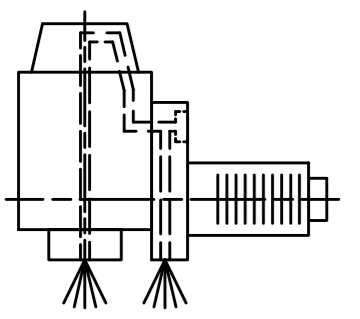

Innen- und Aussenkuehlung / Inside and outside coolant supply  
 Kuehlmittelfiltrierung<50µ / coolant filtration<50µ

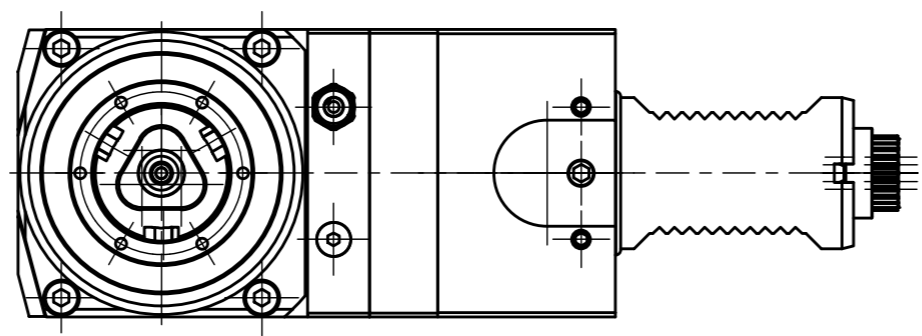

Doppelverzahnung Lizenz Traub  
 double tooth system licence Traub

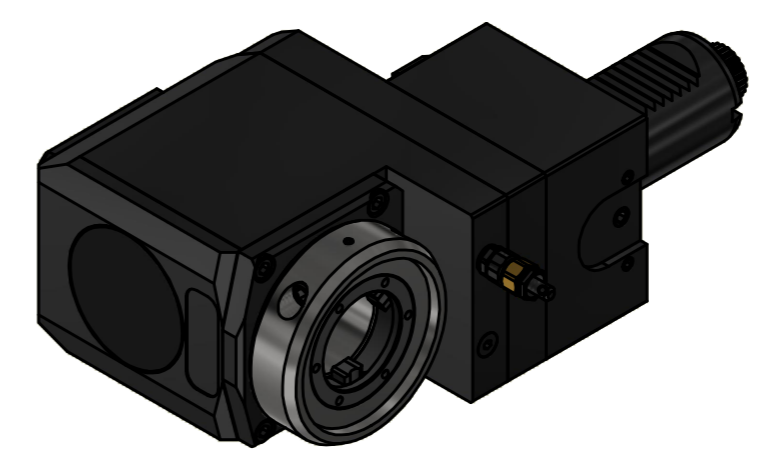

Copyright **EWS Tool Technologies**  
 Weitergabe und Vervielfaeltigung dieser Unterlage,  
 Verwertung und Mitteilung ihres Inhalts nicht  
 gestattet, soweit nicht ausdrecklich zugestanden.  
 Zuwiderhandlungen verpflichten zu Schadenersatz.

Bemerkung - Note Für Trockenlauf geeignet! Use without coolant fluid allowed!	Technische Daten - technical data <b>Weight</b> = 8.475 [kg]
	<b>Torque max.</b> (M1/M2) = 63 / 63 [Nm]
	<b>Speed max.</b> (n1/n2) = 6000 / 6000 [1/min]
	<b>Gear ratio</b> (i)=n1:n2 = 1:1
	<b>Pressure</b> (pmax) = 70 [bar]

Benennung - Title  
**Radial Bohr und Fräskopf, zurückges**  
**Radial drill. and mill. head offset**

<b>EWS</b> Tool Technologies <small>EWS Weigle GmbH &amp; Co. KG          Maybachstr. 1          D-73066 Uhlingen          www.ews-tools.de</small>	Technische Aenderungen vorbehalten! Subject to technical modifications! IDENT: DEWS268938	MNR. REV: -/A
	Nr. - No. <b>80.40VX4LCTXRLIKD#01</b>	<b>233332</b>

