

Butterfly Seal Polygon Joint Coolant Management Tech Details

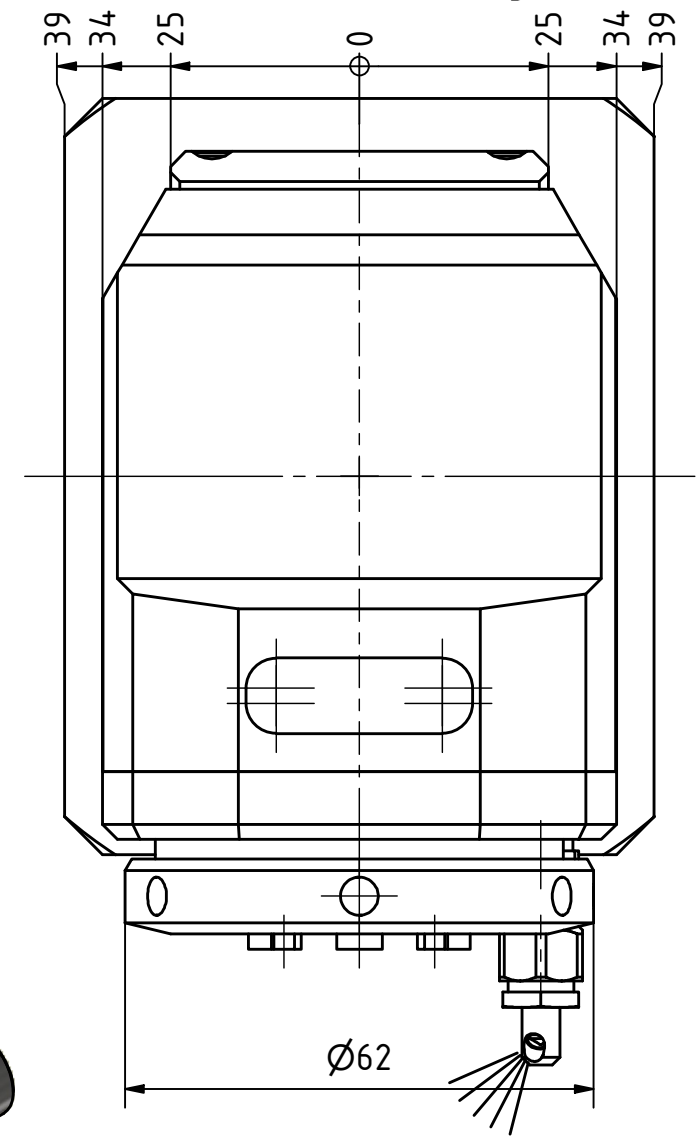

Spannzange / collet ER25 DIN6499  
Spannbereich / clamping range: 1,0 - 16,0

Gewindebohrzange / tapping collet  
ET-1-25 M3-M10

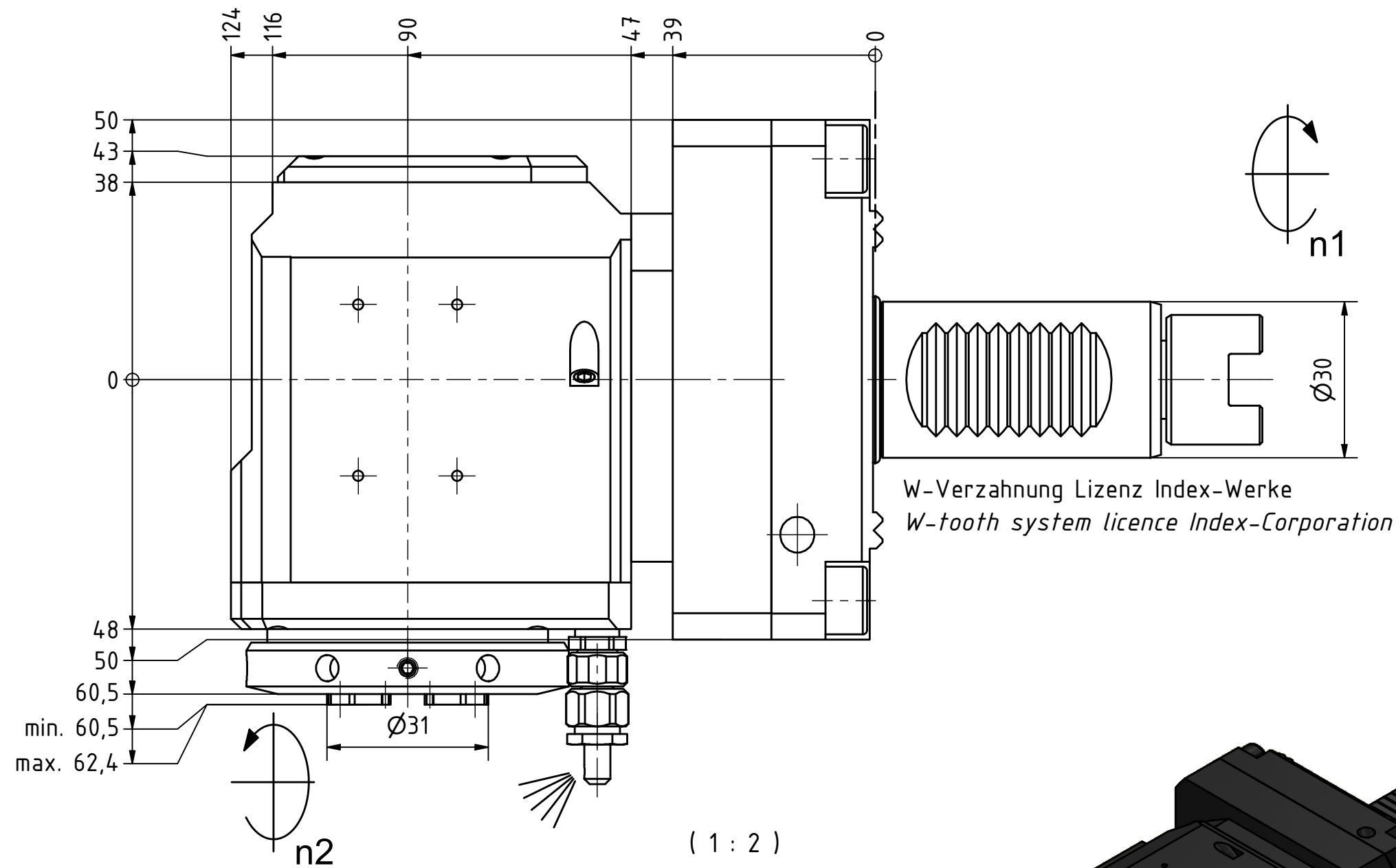
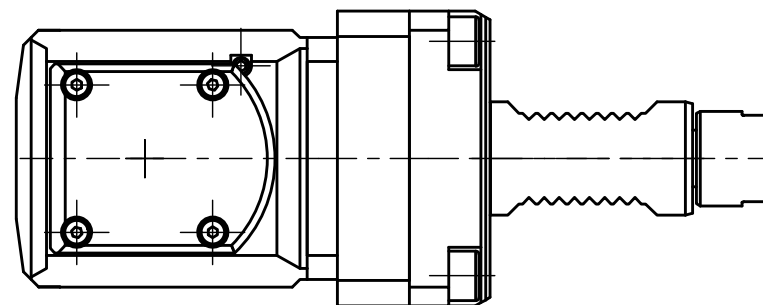

Doppelverzahnung Lizenz Traub  
double tooth system licence Traub

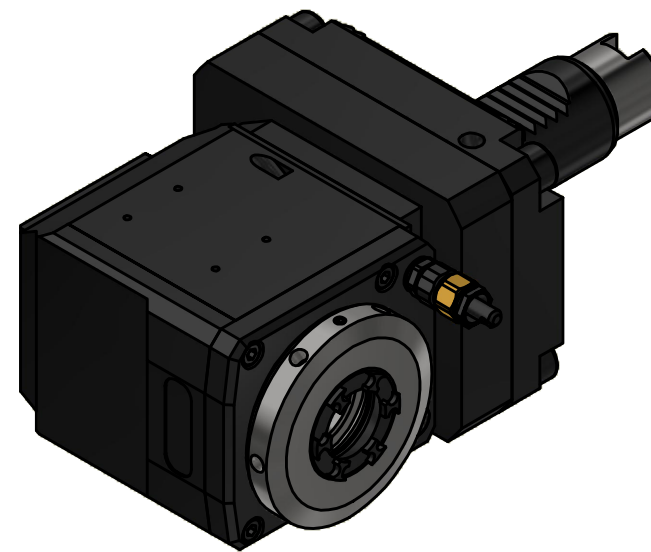

Spannzangenschlüssel für  
innenliegende Mutter  
Clamping wrench for  
internal collet  
225AX

Hakenschlüssel  
mit Zapfen  
Hook wrench  
with fixed pin  
DIN1810 B 58x62

Copyright **EWS Tool Technologies**  
Weitergabe und Vervielfältigung dieser Unterlage,  
Verwertung und Mitteilung ihres Inhalts nicht  
gestattet, soweit nicht ausdrücklich zugestanden.  
Zu widerhandlungen verpflichten zu Schadenersatz.

Bemerkung - Note  
mit Kegelrollenlager  
with taper roller bearing(s)

Technische Daten - technical data  
Weight = 5.526 [kg]  
Torque max. (M1/M2) = 20 / 40 [Nm]  
Speed max. (n1/n2) = 8000 / 4000 [1/min]  
Gear ratio (i)=n1:n2 = 2:1

Benennung - Title  
**Radial Bohr und Fräskopf**  
**Radial drilling and milling head**



Nr. - No.  
60.3025KRG300RLI2WIM

Technische Änderungen vorbehalten!  
Subject to technical modifications!  
IDENT: DEWS268733

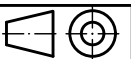

REV: -/A

MNR.

233269

