

Hakenschlüssel mit Zapfen
Hook wrench with fixed pin
DIN1810 B 58x62

Spannzangenschlüssel für innenliegende Mutter
Clamping wrench for internal collet
225AX

Copyright EWS Tool Technologies
Weitergabe und Vervielfältigung dieser Unterlage, Verwertung und Mitteilung ihres Inhalts nicht gestattet, soweit nicht ausdrücklich zugestanden. Zuwiderhandlungen verpflichten zu Schadenersatz.

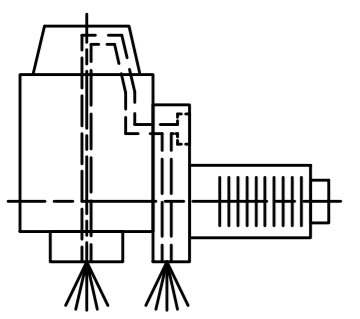
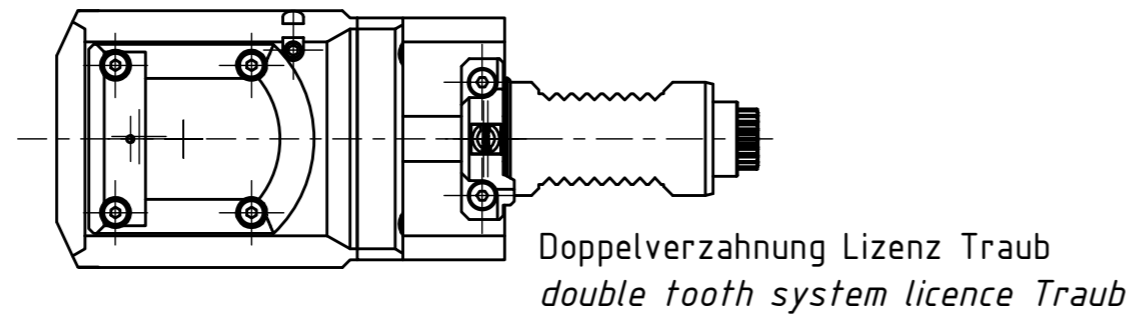

Innen- und Aussenkuehlung / Inside and outside coolant supply
Kuehlmittefiltrierung<50µ / coolant filtration<50µ

Bemerkung - Note Für Trockenlauf geeignet! Use without coolant fluid allowed!	Technische Daten - technical data
	Weight = 4.776 [kg]
	Torque max. (M1/M2) = 32 / 32 [Nm]
	Speed max. (n1/n2) = 12000 / 12000 [1/min]
	Gear ratio (i)=n1:n2 = 1:1
Pressure (pmax) = 70 [bar]	

Benennung - Title
Radial Bohr und Fräskopf, zurückges
Radial drill. and mill. head offset

 <small>EWS Weigle GmbH & Co. KG Maybachstr. 1 D-73066 Ulm/Ingden www.ews-tool.de</small>	<small>Technische Änderungen vorbehalten! Subject to technical modifications!</small> IDENT: DEWS268595	 <small>MNR</small> REV: -/A	
	<small>Nr. - No.</small> 80.3025GT300RLIKDTRIMHSD12	<small>REV: -/A</small> 233265	