

Spannzange / collet ER25 DIN6499
 Spannungsbereich / clamping range: 1,0 - 16,0

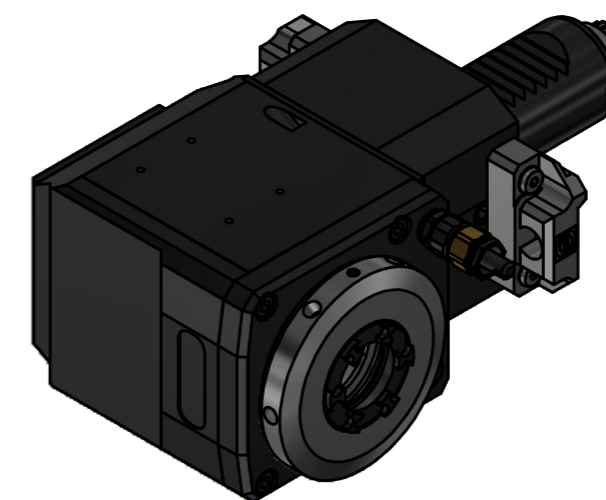
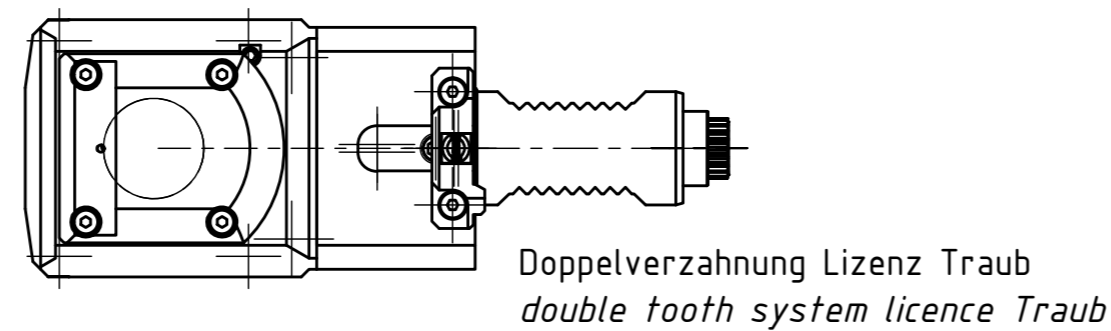

Hakenschlüssel mit Zapfen
 Hook wrench with fixed pin
 DIN1810 B 58x62

Spannzangenschlüssel für innenliegende Mutter
 Clamping wrench for internal collet
 225AX

Copyright EWS Tool Technologies
 Weitergabe und Vervielfältigung dieser Unterlage, Verwertung und Mitteilung ihres Inhalts nicht gestattet, soweit nicht ausdrücklich zugestanden. Zuwiderhandlungen verpflichten zu Schadenersatz.

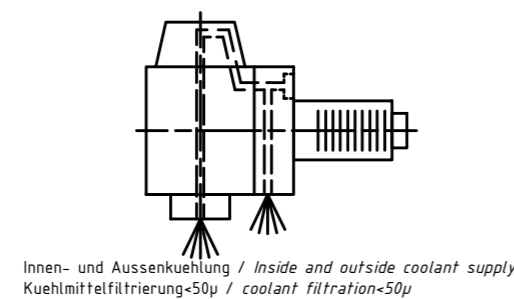

Bemerkung - Note Für Trockenlauf geeignet! Use without coolant fluid allowed!	Technische Daten - technical data Weight = 4.318 [kg]
	Torque max. (M1/M2) = 32 / 32 [Nm]
	Speed max. (n1/n2) = 12000 / 12000 [1/min]
	Gear ratio (i)=n1:n2 = 1:1
	Pressure (pmax) = 70 [bar]

Benennung - Title
Radial Bohr und Fräskopf
Radial drilling and milling head

EWS Tool Technologies <small>EWS Weigle GmbH & Co. KG Maybachstr. 1 D-73066 Ulm/ingen www.ews-tools.de</small>	Technische Änderungen vorbehalten! Subject to technical modifications! IDENT: DEWS268292	REV: -/A MNR.
	Nr. - No. 60.3025GT300RLIKDTRIMHSD12	233245

