

Spannzange / collet ER25 DIN6499
Spannbereich / clamping range: 1,0 - 16,0

Gewindebohrzange / tapping collet
ET-1-25 M3-M12

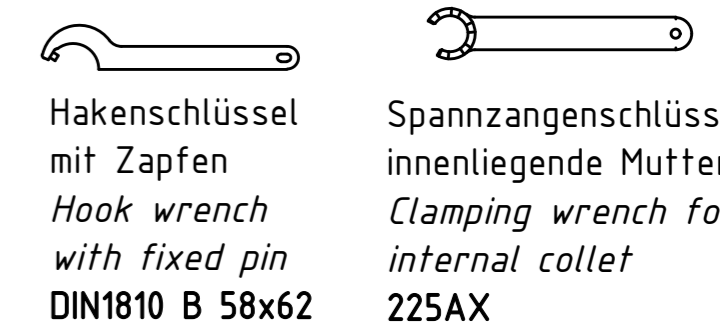
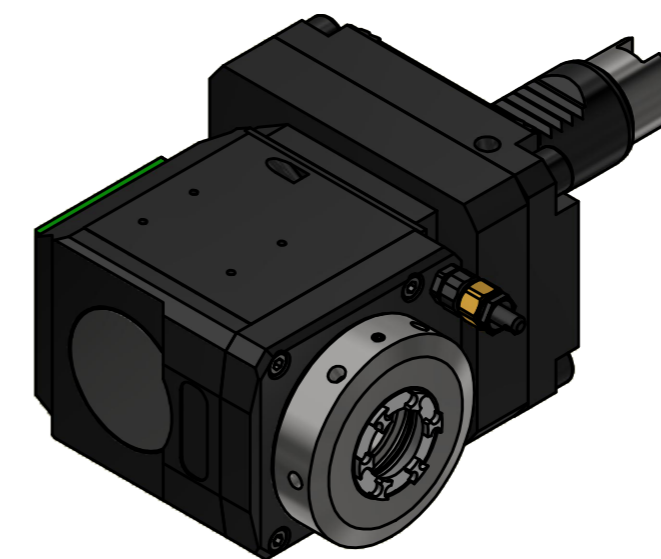
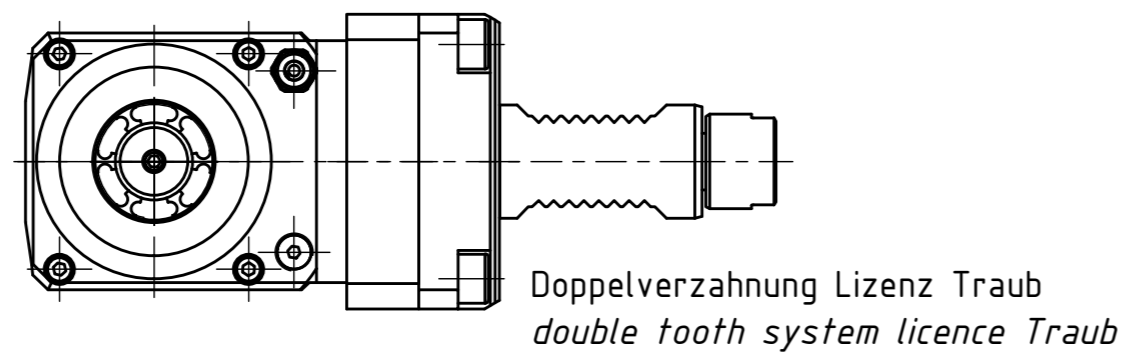

Copyright **EWS Tool Technologies**
Weitergabe und Vervielfältigung dieser Unterlage, Verwertung und Mitteilung ihres Inhalts nicht gestattet, soweit nicht ausdrücklich zugestanden. Zuwiderhandlungen verpflichten zu Schadenersatz.

Bemerkung - Note	Technische Daten - technical data Weight = 5,740 [kg] Torque max. (M1/M2) = 32 / 32 [Nm] Speed max. (n1/n2) = 8000 / 8000 [1/min] Gear ratio (i)=n1:n2 = 1:1	Benennung - Title Radial Bohr und Fräskopf Radial drilling and milling head	 EWS Weigle GmbH & Co. KG Maybachstr. 1 D-73066 Uhlingen www.ews-tool.de	Technische Änderungen vorbehalten! Subject to technical modifications! IDENT: DEWS266796 Nr. - No. 60.3025G300RLGLWIM MNR. 233032	
------------------	--	---	--	---	--