

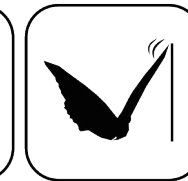

Ceramic Seal

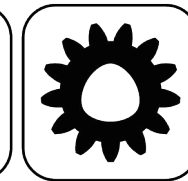

Butterfly Seal



Polygon Joint

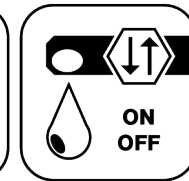

Coolant Management

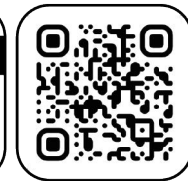

Tech Details

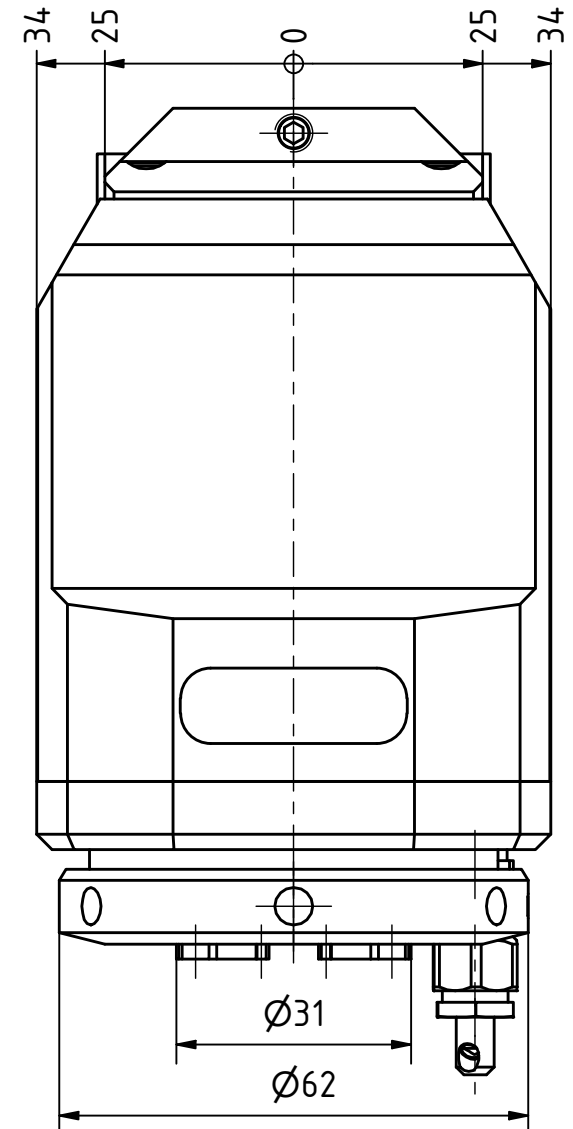
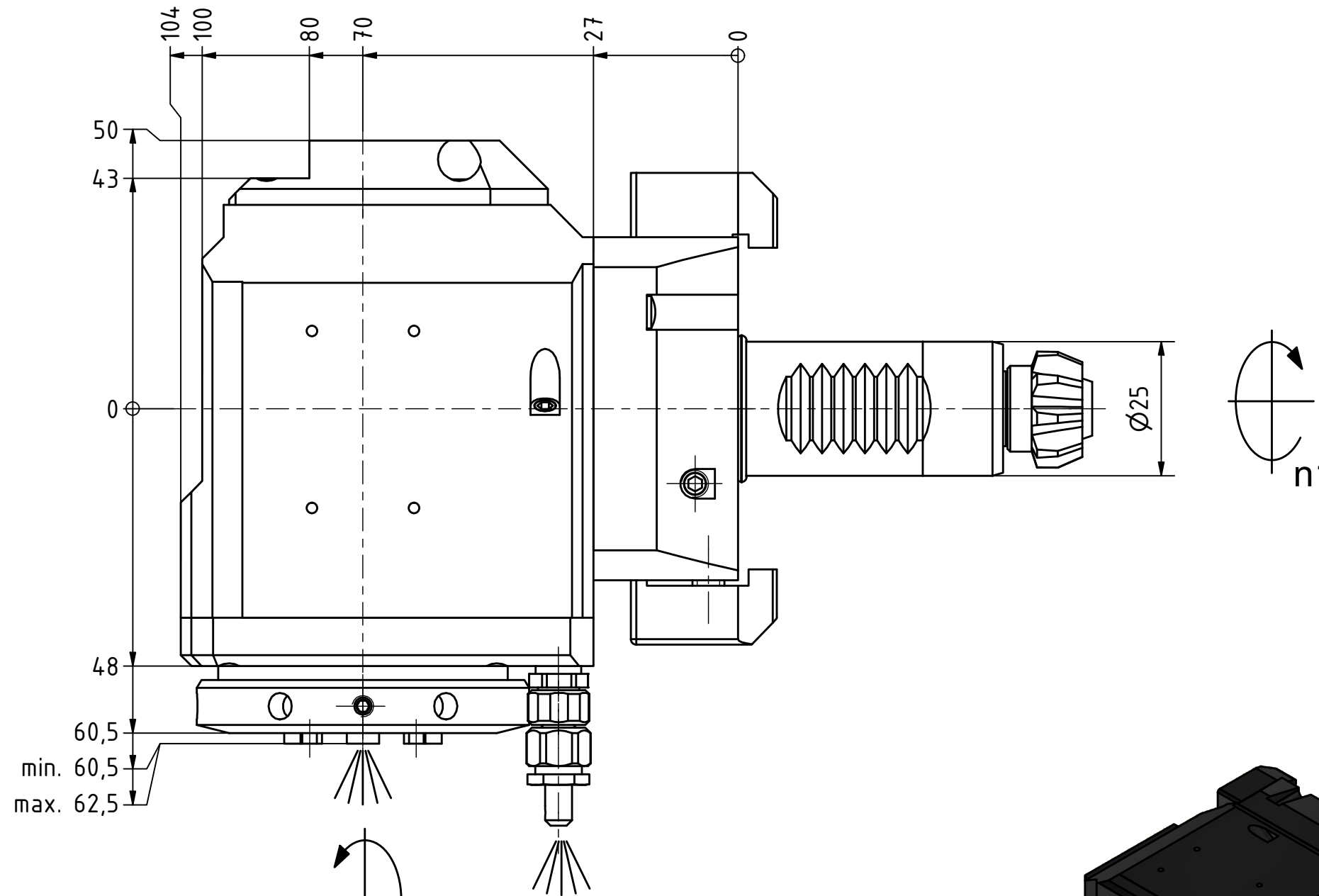

Spannzange / collet ER25 DIN6499
Spannbereich / clamping range: 1,0 - 16,0

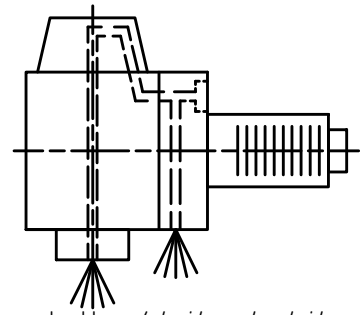

Innen- und Aussenkuehlung / Inside and outside coolant supply
Kuehlmittelfiltrierung <math>< 50\mu</math> / coolant filtration <math>< 50\mu</math>

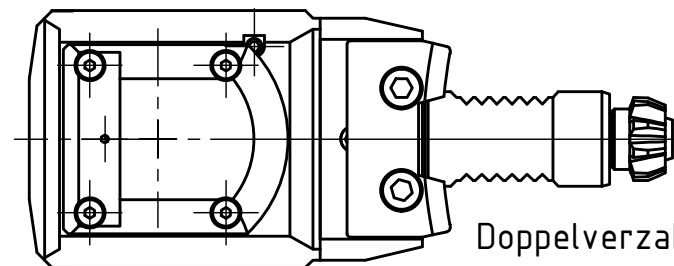

Doppelverzahnung Lizenz Traub
double tooth system licence Traub

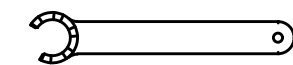
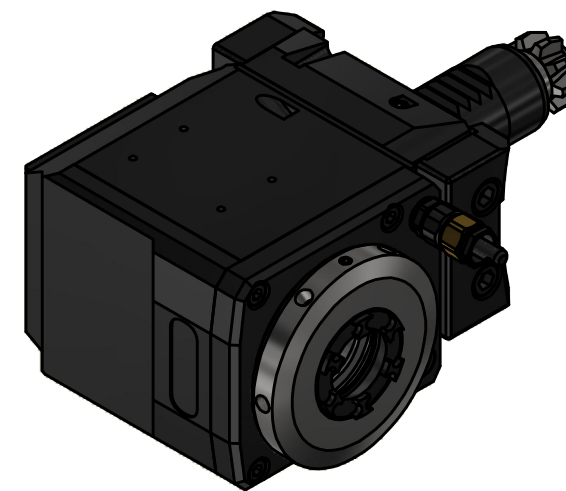

Spannzangenschlüssel für innenliegende Mutter
Clamping wrench for internal collet
225AX

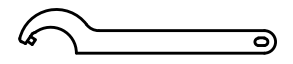

Hakenschlüssel mit Zapfen
Hook wrench with fixed pin
DIN1810 B 58x62

Copyright **EWS Tool Technologies**
Weitergabe und Vervielfaeltigung dieser Unterlage, Verwertung und Mitteilung ihres Inhalts nicht gestattet, soweit nicht ausdrecklich zugestanden. Zuwiderhandlungen verpflichten zu Schadenersatz.

Bemerkung - Note
Für Trockenlauf geeignet!
Use without coolant fluid allowed!

Technische Daten - technical data
Weight = 4.065 [kg]
Torque max. (M1/M2) = 25 / 25 [Nm]
Speed max. (n1/n2) = 8000 / 8000 [1/min]
Gear ratio (i)=n1:n2 = 1:1
Pressure (pmax) = 70 [bar]

Benennung - Title
Radial Bohr und Fräskopf
Radial drilling and milling head



Nr. - No.
60.2525ABCRLIKDIM

Technische Aenderungen vorbehalten!
Subject to technical modifications!
IDENT: DEWS266049

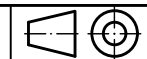

REV: -/A

MNR.
232949

