

Spannzange / collet ER32 DIN6499
 Spannbereich / clamping range: 2,0 - 20,0

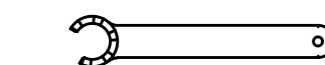

Spannzangenschlüssel für innenliegende Mutter
 Clamping wrench for internal collet
 232AX

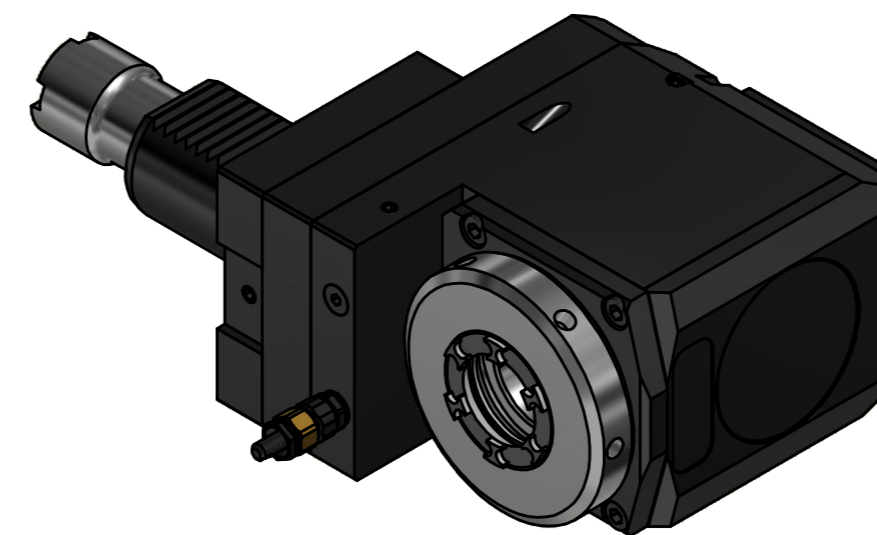
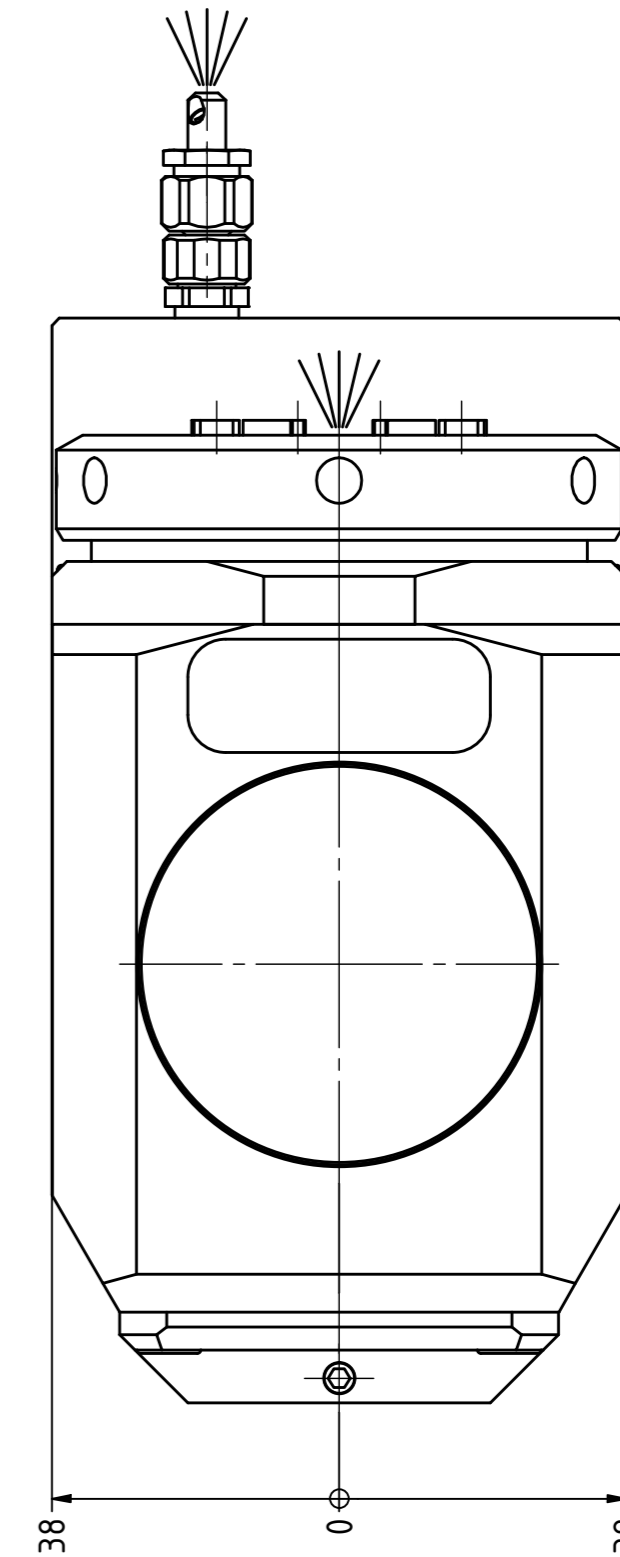
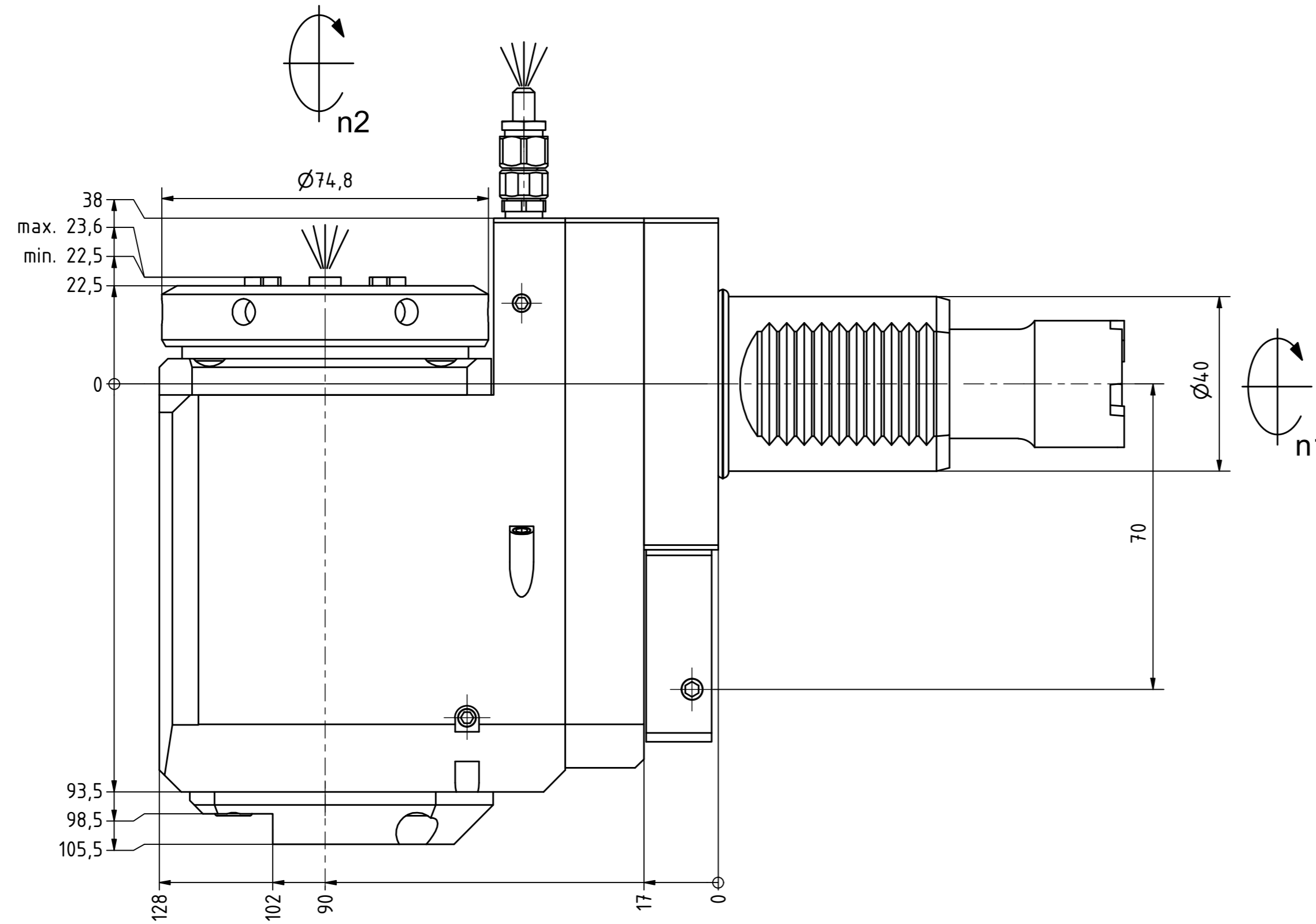
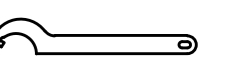

Hakenschlüssel mit Zapfen
 Hook wrench with fixed pin
 DIN1810 B 68x75

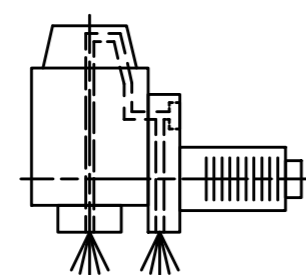

Innen- und Aussenkuehlung / Inside and outside coolant supply
 Kuehlmittefiltrierung=50µ / coolant filtration=50µ

Bemerkung - Note
 Für Trockenlauf geeignet!
 Use without coolant fluid allowed!

Technische Daten - technical data
 Weight = 7.434 [kg]
 Torque max. (M1/M2) = 63 / 63 [Nm]
 Speed max. (n1/n2) = 6000 / 6000 [1/min]
 Gear ratio (i)=n1:n2 = 1:1
 Pressure (pmax) = 70 [bar]

Benennung - Title
 Radial Bohr und Fräskopf, zurückges
 Radial drill. and mill. head offset

EWS Tool Technologies
 Nr. - No.
 80.4032LB15LIKDIM

Technische Aenderungen vorbehalten!
 Subject to technical modifications!
 IDENT: DEWS265883

REV: -/A
 MNR.
 232937



Copyright EWS Tool Technologies
 Weitergabe und Vervielfaeltigung dieser Unterlage,
 Verwertung und Mitteilung ihres Inhalts nicht
 gestattet, soweit nicht ausdrecklich zugestanden.
 Zuwiderhandlungen verpflichten zu Schadenersatz.