

Trifix Anzugsdrehmoment 25 Nm
Trifix clamping torque 25 Nm

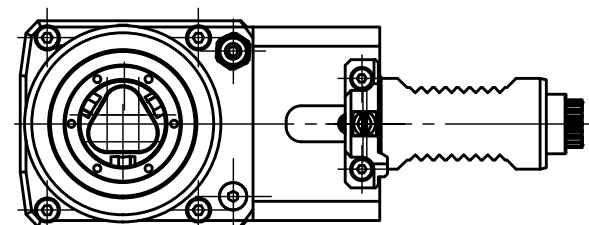

Doppelverzahnung Lizenz Traub
double tooth system licence Traub

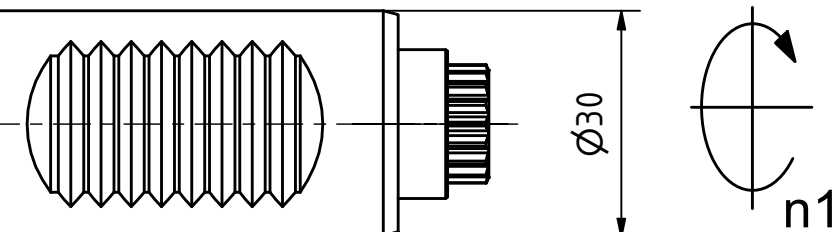
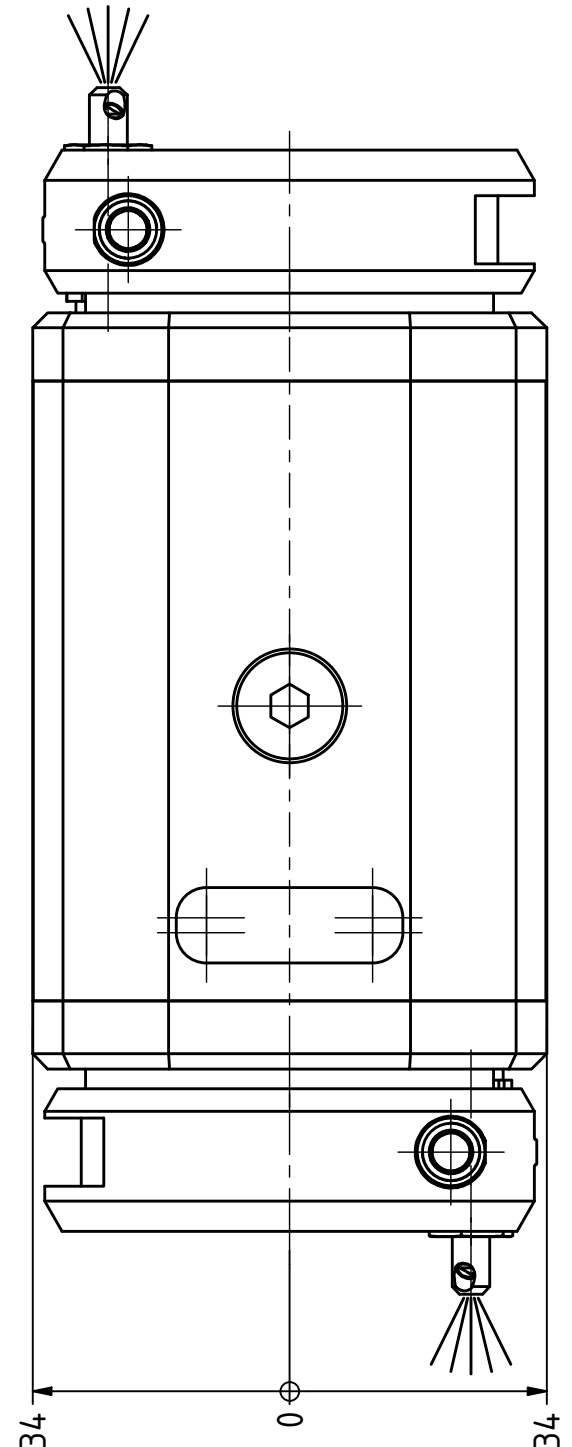
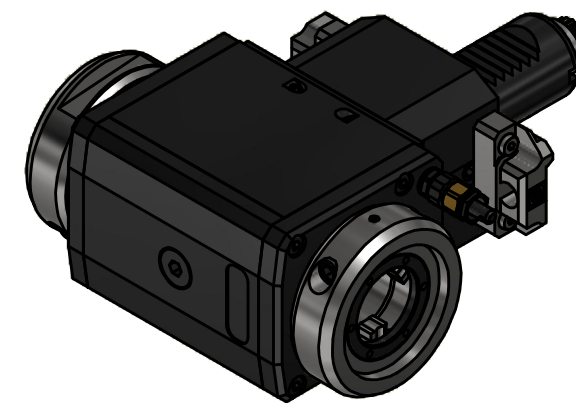

Copyright **EWS Tool Technologies**
Weitergabe und Vervielfaeltigung dieser Unterlage,
Verwertung und Mitteilung ihres Inhalts nicht
gestattet, soweit nicht ausdrecklich zugestanden.
Zuwiderhandlungen verpflichten zu Schadenersatz.

Bemerkung - Note

Technische Daten - technical data

Weight	= 5.405 [kg]
Torque max. (M1/M2)	= 32 / 32 32 [Nm]
Speed max. (n1/n2)	= 8000 / 8000 8000 [1/min]
Gear ratio (i)=n1:n2	= 1:1 1:1

Benennung - Title

Radial Bohr und Fräskopf
Radial drilling and milling head

EWS Tool Technologies
EWS Weigle GmbH & Co. KG
Maybachstr. 1
D-73066 Uhingen
www.ews-tools.de

Nr. - No.
60.30VX3DGT300RLTF

Technische Aenderungen vorbehalten!
Subject to technical modifications!

IDENT: DEWS265631

REV: -/A

MNR.
232857

