

Bitte überprüfen Sie, ob der Werkzeughalter auf ihrem Revolver im Maschinenraum ohne Kollision durchschwenken kann.
 Please check the work space of the machine for interferences with the tool holder, especially the swiveling diameter.

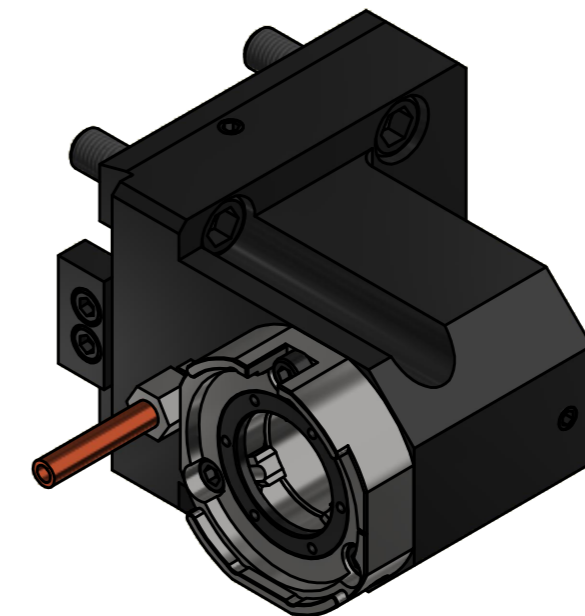
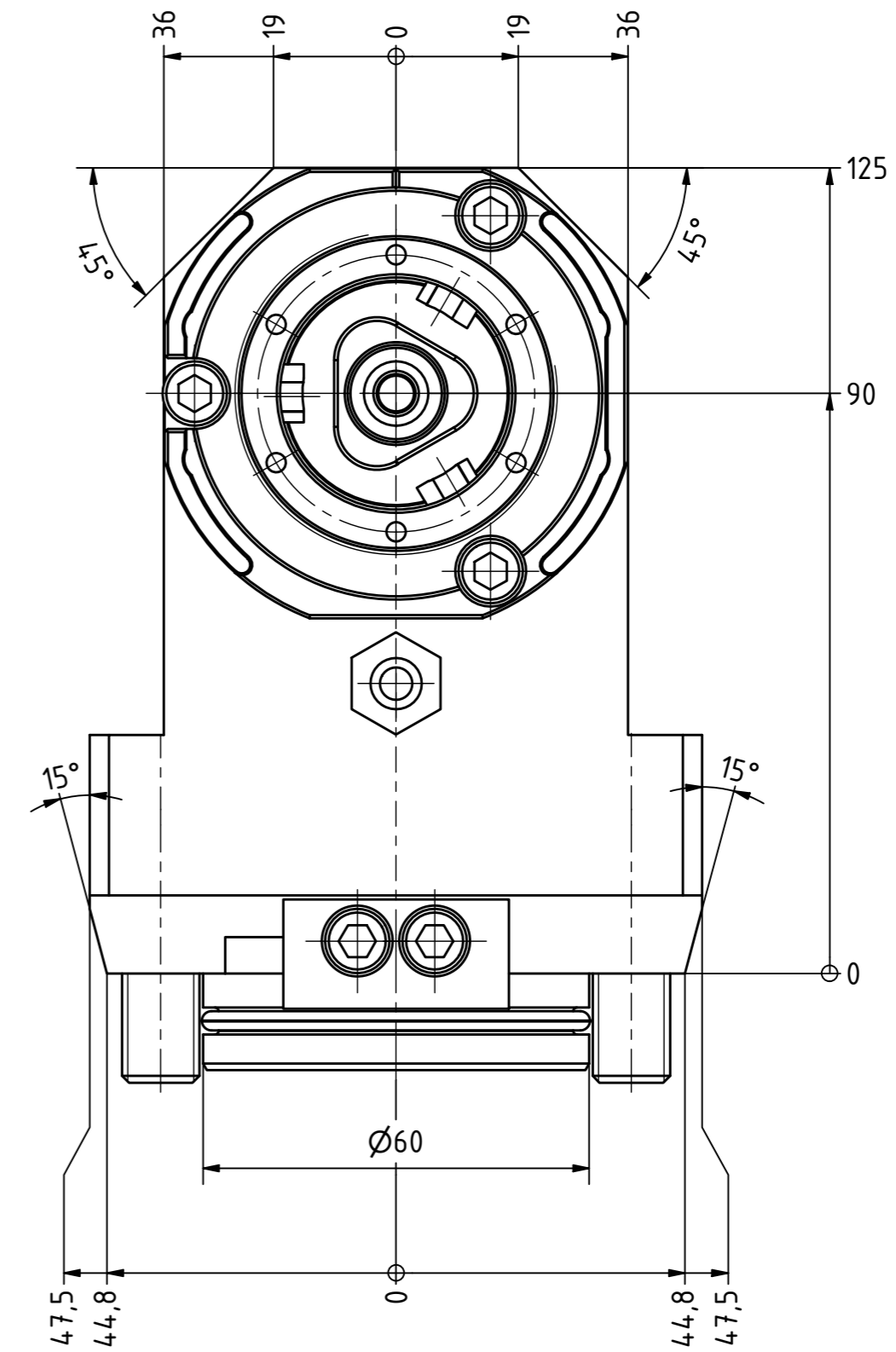
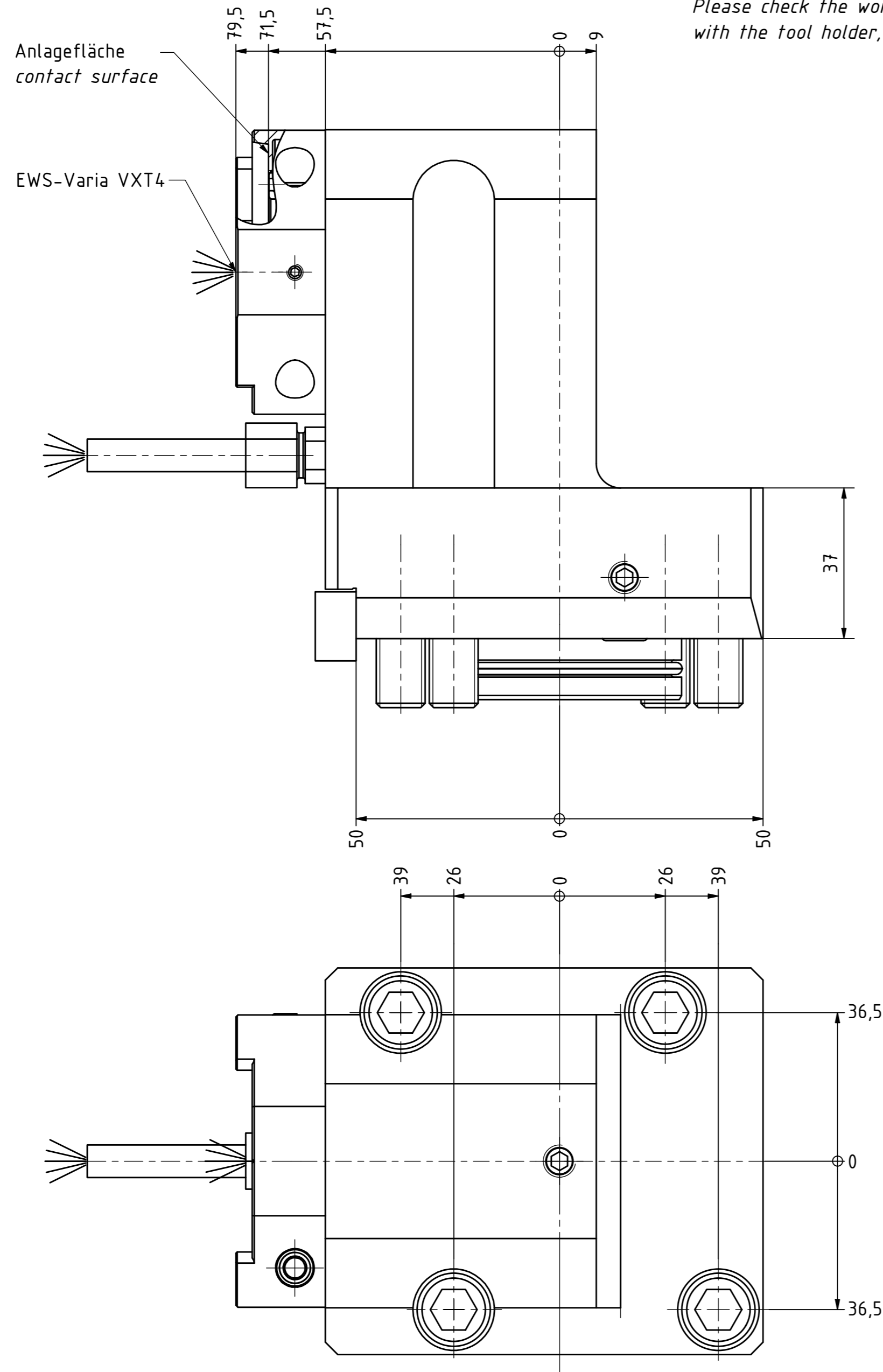

Schaftstück muss für Okuma Multus U3000/U4000 demontiert werden
 shank piece must be removed for Okuma Multus U3000/U4000

Bemerkung - Note Technische Daten - technical data Weight = 6.153 [kg]	Benennung - Title Werkzeugaufnahme Tool adaptor	 EWS Weigle GmbH & Co. KG Maybachstr. 1 D-73066 Uhlingen www.ews-tools.de Nr. - No. 19.BMTVXT4LB2000	Technische Änderungen vorbehalten! Subject to technical modifications! IDENT: DEWS266435 MNR. 232639	 REV: -/B QR
--	---	---	---	---

Copyright **EWS Tool Technologies**
 Weitergabe und Vervielfältigung dieser Unterlage,
 Verwertung und Mitteilung ihres Inhalts nicht
 gestattet, soweit nicht ausdrücklich zugestanden.
 Zuwiderhandlungen verpflichten zu Schadenersatz.