

Doppelverzahnung Lizenz Traub
double tooth system licence Traub

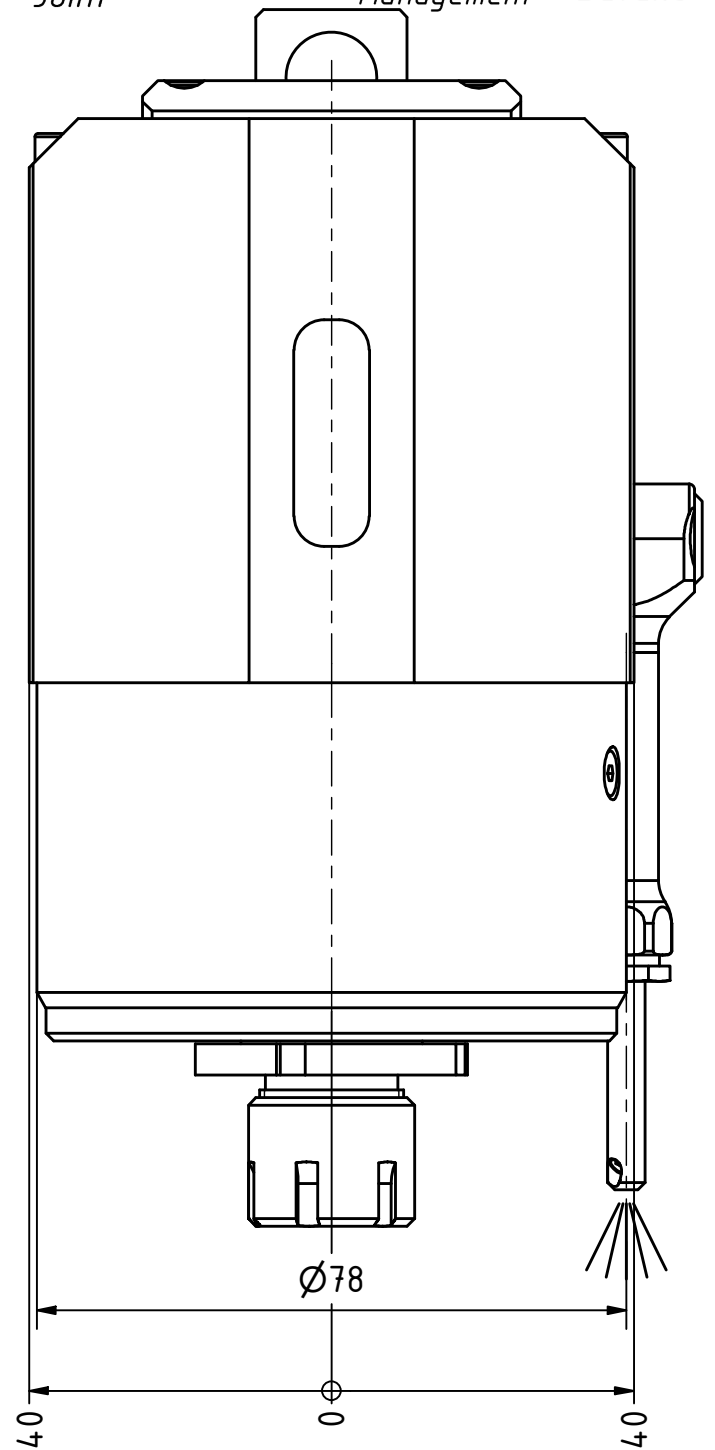
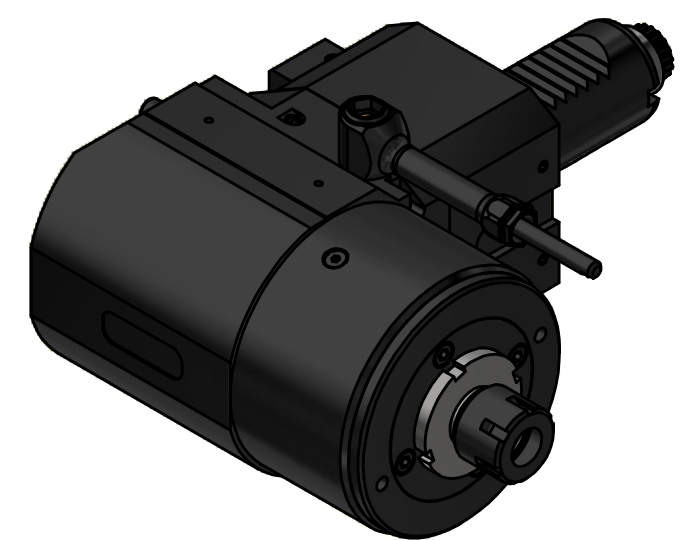
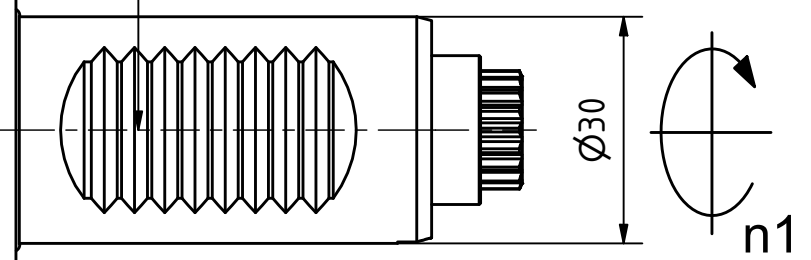
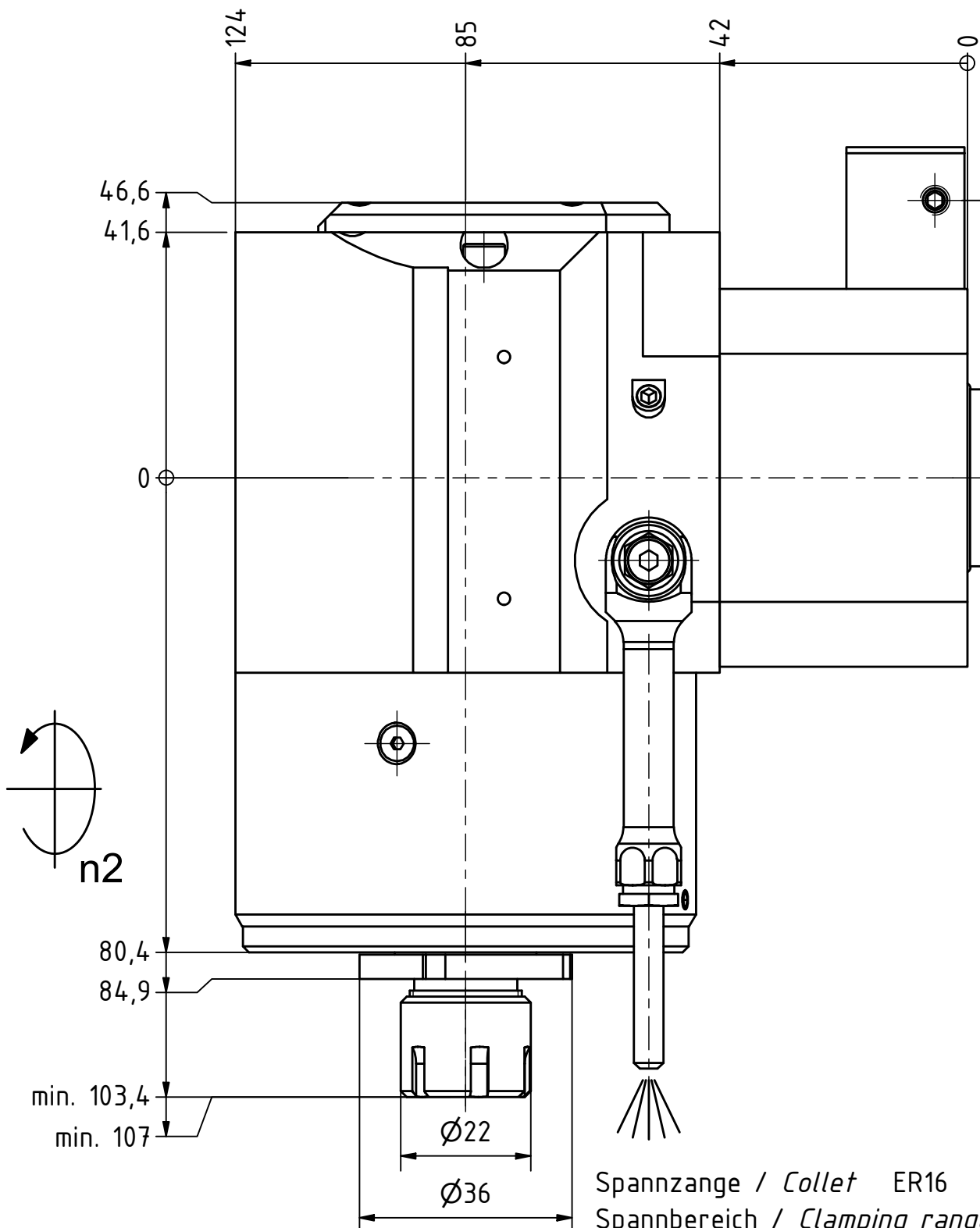

Spannzange / Collet ER16 DIN6499
Spannbereich / Clamping range: 1,0 - 10,0

Gewindebohrzange / Tapping Collet
ET-1-16 M1-M6

Hakenschlüssel
mit Nase
Hook wrench with
nose end
DIN1810 A 36x38

Spannzangenschlüssel
Clamping wrench
216 M

Fettschmierung mit Klüber Isoflex NCA 15
Alle 100 Betriebsstunden mit ca. 1cm³ Fett nachschmieren
Grease lubrication with Klüber Isoflex NCA 15
relubricate every 100 operating hours with about 1cm³ of grease

Copyright **EWS Tool Technologies**
Weitergabe und Vervielfältigung dieser Unterlage,
Verwertung und Mitteilung ihres Inhalts nicht
gestattet, soweit nicht ausdrücklich zugestanden.
Zu widerhandlungen verpflichten zu Schadenersatz.

Bemerkung - Note

Technische Daten - technical data	
Weight	= 5.771 [kg]
Torque max. (M1/M2)	= 25 / 5 [Nm]
Speed max. (n1/n2)	= 4800 / 24.000 [1/min]
Gear ratio (i)=n1:n2	= 1:5

Benennung - Title
Radial Bohr und Fräskopf
Radial drilling and milling head

EWS Tool Technologies
EWS Weigle GmbH & Co. KG
Maybachstr. 1
D-73066 Utingen
www.ews-tools.de

Technische Änderungen vorbehalten! Subject to technical modifications!	
IDENT: DEWS264792	REV: -/A
Nr. - No.	MNR.
60.3016GT300RLI15#01	232720

