

Butterfly Seal

Polygon Joint

Coolant Management

Tech Details

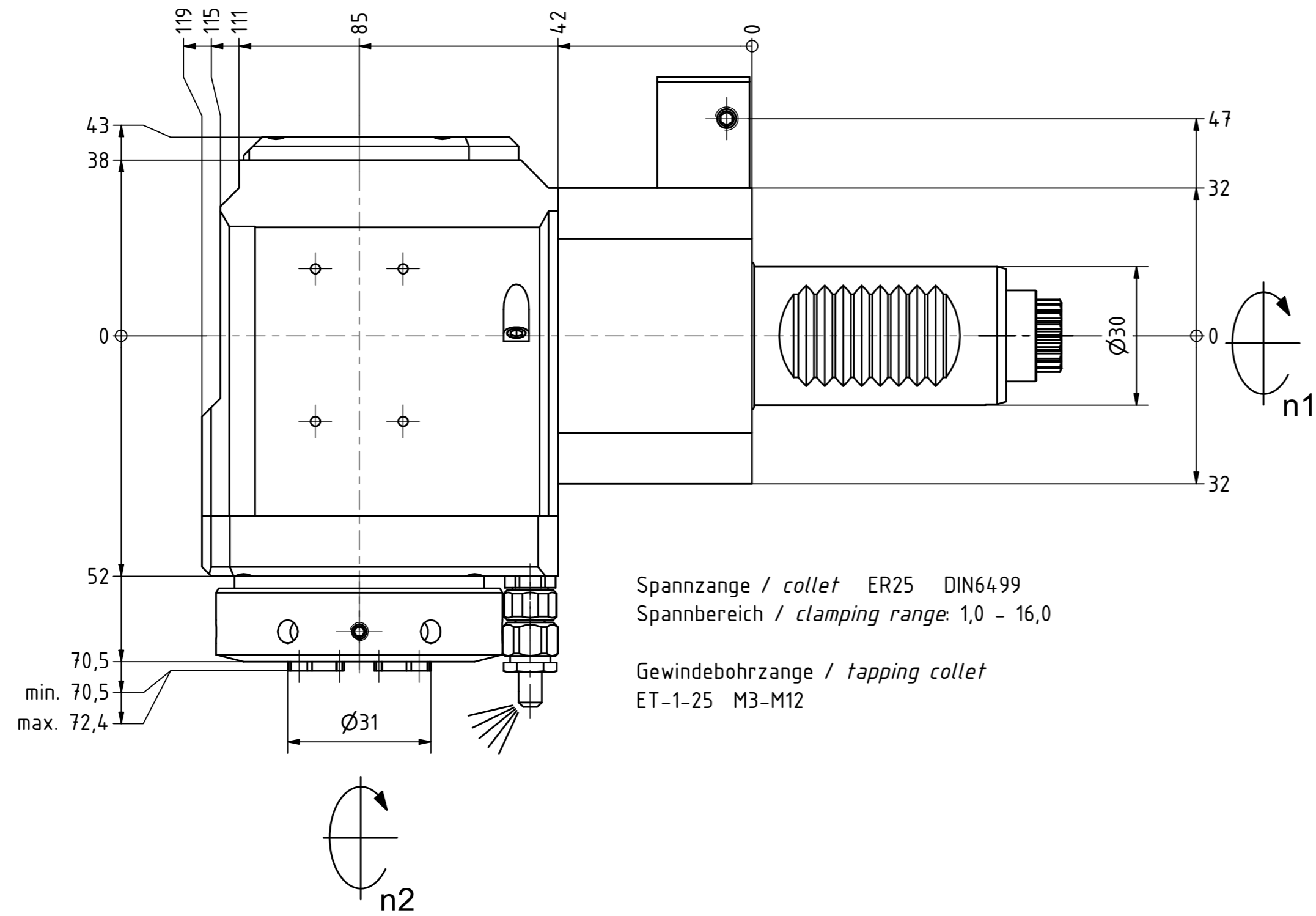

Spannzange / collet ER25 DIN6499  
Spannbereich / clamping range: 1,0 - 16,0

Gewindebohrzange / tapping collet  
ET-1-25 M3-M12

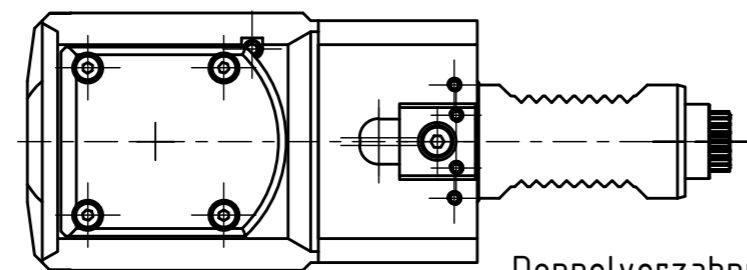
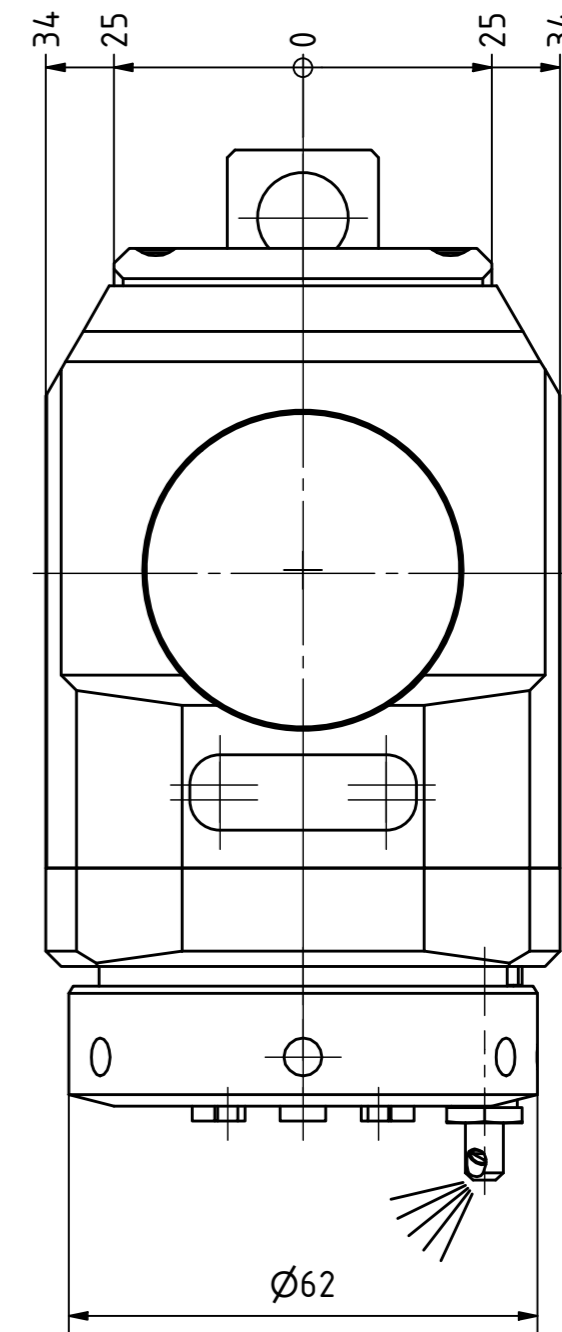

Doppelverzahnung Lizenz Traub  
double tooth system licence Traub

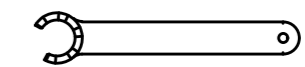
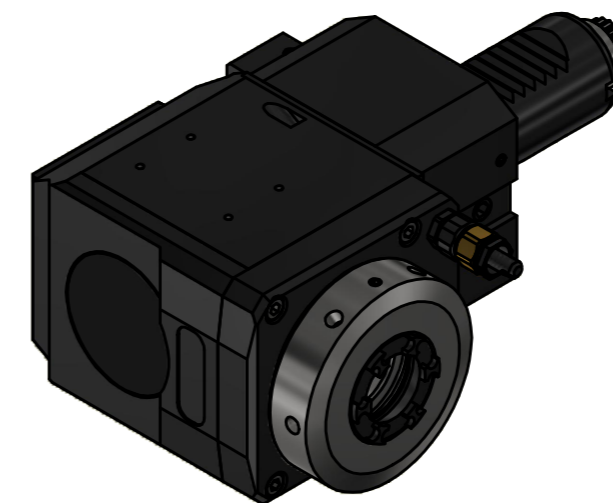

Spannzangenschlüssel für  
innenliegende Mutter  
Clamping wrench for  
internal collet  
225AX

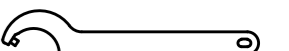

Hakenschlüssel  
mit Zapfen  
Hook wrench  
with fixed pin  
DIN1810 B 58x62

Copyright **EWS Tool Technologies**  
Weitergabe und Vervielfältigung dieser Unterlage,  
Verwertung und Mitteilung ihres Inhalts nicht  
gestattet, soweit nicht ausdrücklich zugestanden.  
Zuwerhandlungen verpflichten zu Schadenersatz.

Bemerkung - Note

Technische Daten - technical data

Weight = 4,464 [kg]  
Torque max. (M1/M2) = 32 / 32 [Nm]  
Speed max. (n1/n2) = 8000 / 8000 [1/min]  
Gear ratio (i)=n1:n2 = 1:1

Benennung - Title

Radial Bohr und Fräskopf  
Radial drilling and milling head



Nr. - No.  
60.3025GT300RLGLIM

Technische Änderungen vorbehalten!  
Subject to technical modifications!  
IDENT: DEWS264640

REV: -/A  
MNR.

232559

