

EWS.Varia

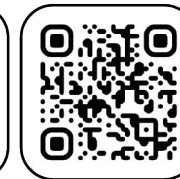

Ceramic Seal



Tech Details

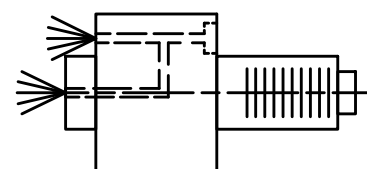
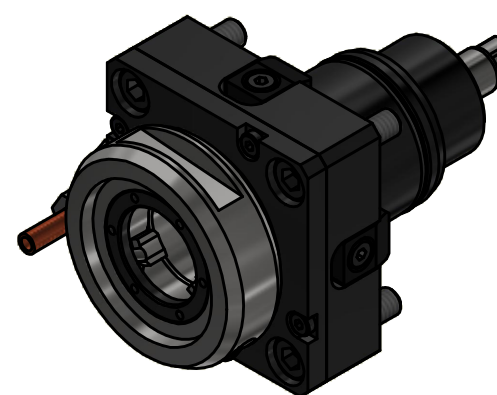
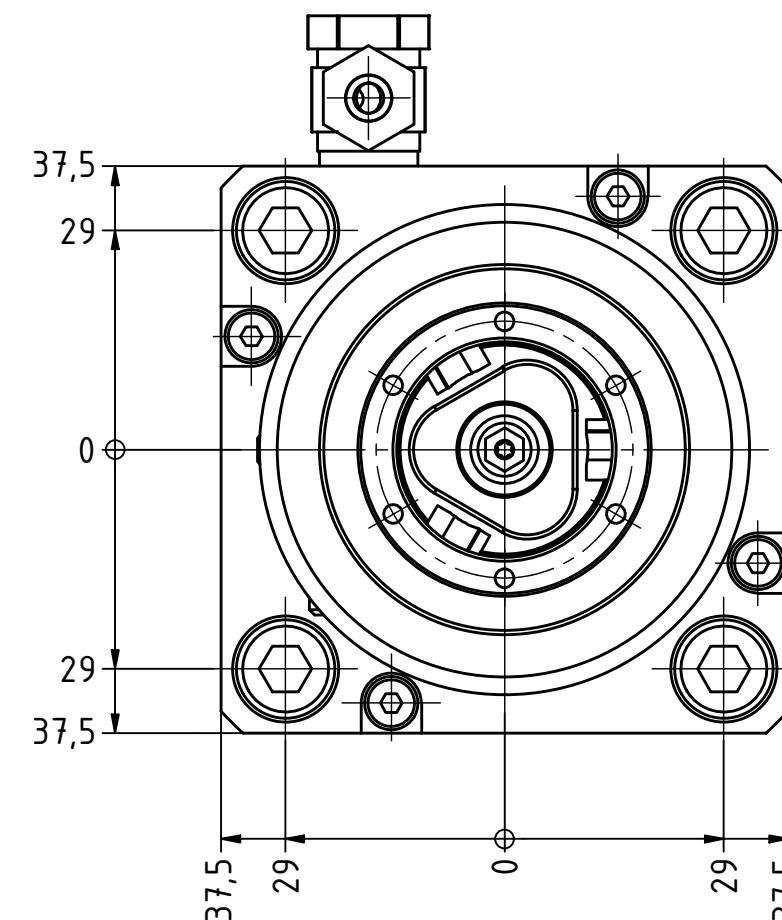
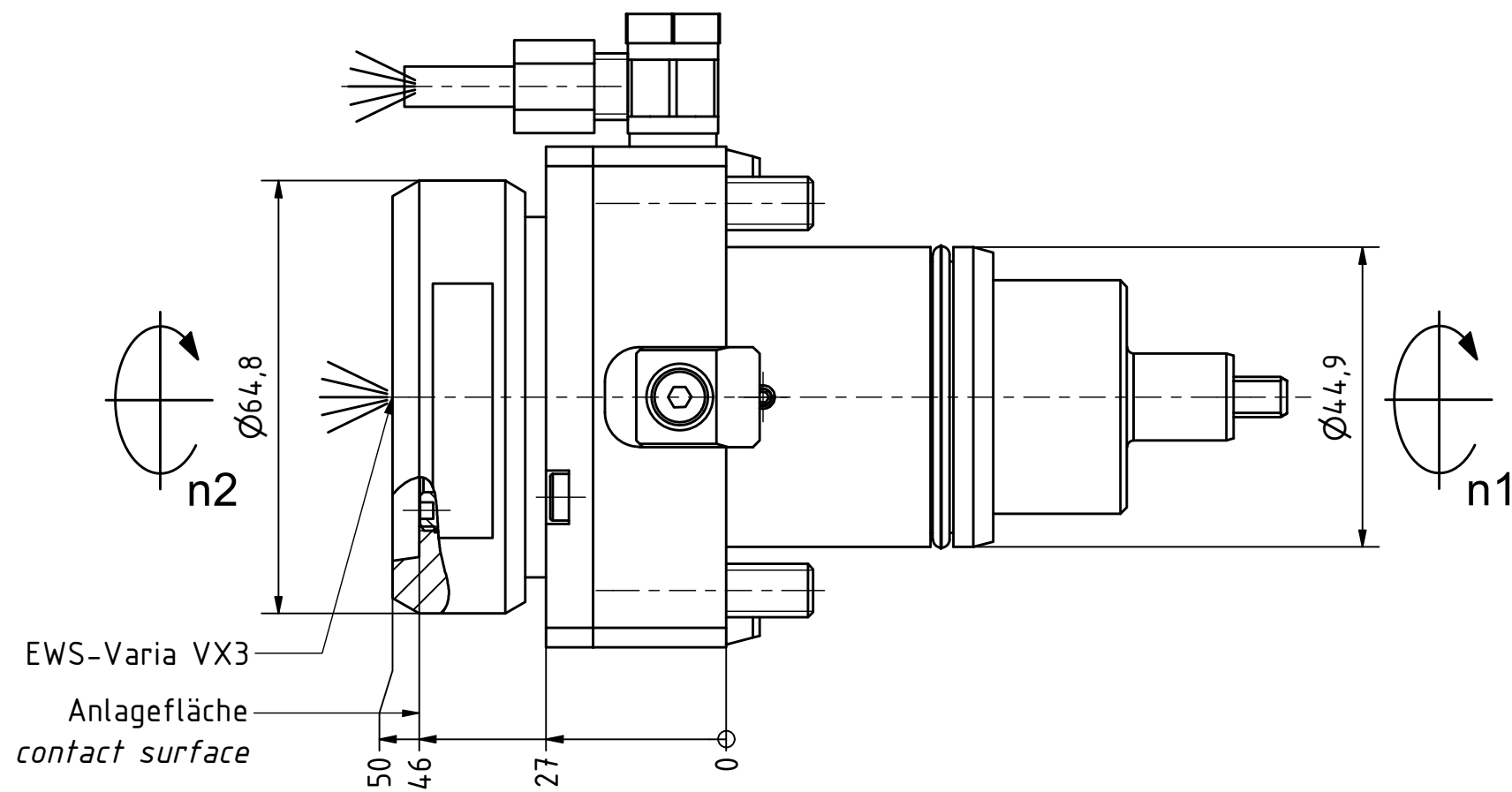

Innen- und Aussenkuehlung / Inside and outside coolant supply
Kuehlmittelfiltrierung50μ / coolant filtration50μ

Copyright **EWS Tool Technologies**

Weitergabe und Vervielfaeltigung dieser Unterlage, Verwertung und Mitteilung ihres Inhalts nicht gestattet, soweit nicht ausdrucklich zugestanden. Zuwiderhandlungen verpflichten zu Schadenersatz.

Bemerkung - Note

Für Trockenlauf geeignet!
Use without coolant fluid allowed!

Technische Daten - technical data

Weight = 2.015 [kg]
 Torque max. (M1/M2) = 25 / 25 [Nm]
 Speed max. (n1/n2) = 6000 / 6000 [1/min]
 Gear ratio (i)=n1:n2 = 1:1
 Pressure (pmax) = 70 [bar]

Benennung - Title

Axial Bohr und Fräskopf
Axial drilling and milling head



Nr. - No.

40.45VX31809HAASIKC

Technische Aenderungen vorbehalten!
Subject to technical modifications!

IDENT: DEWS252610



REV: -/A

MNR.

228274

