

ABS 100
(Lizenz Komet)

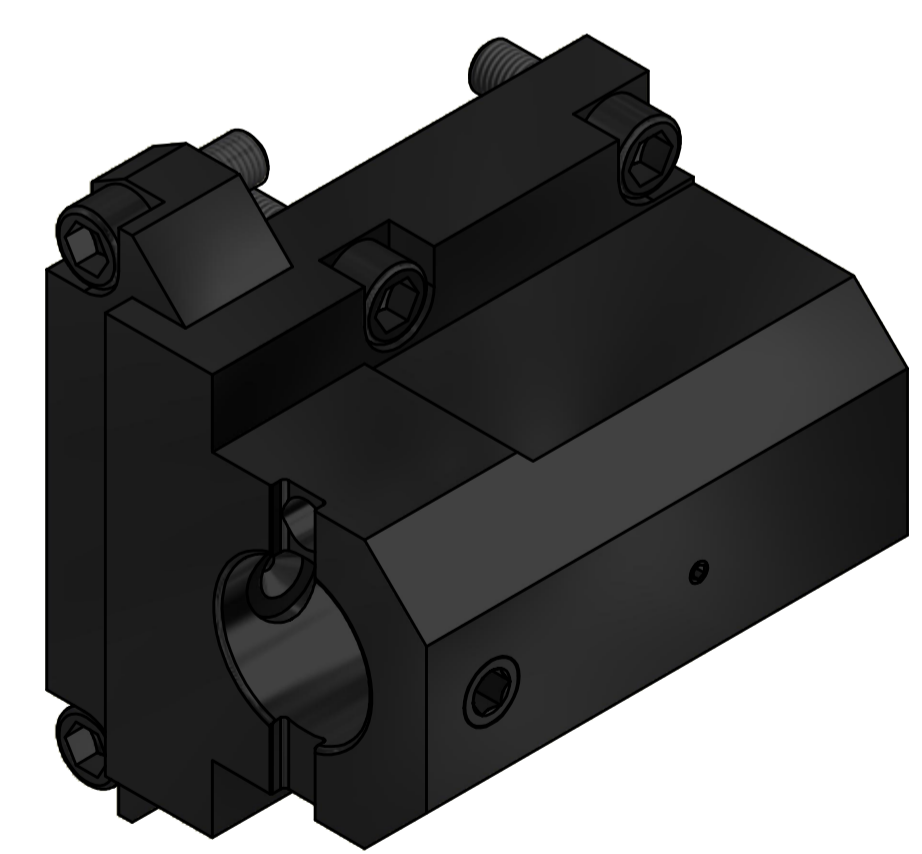

Copyright EWS Tool Technologies
Weitergabe und Vervielfältigung dieser Unterlage,
Verwertung und Mitteilung ihres Inhalts nicht
gestattet, soweit nicht ausdrücklich zugestanden.
Zu widerhandlungen verpflichten zu Schadenersatz.

Bemerkung - Note 	Technische Daten - technical data Weight = 19.741 [kg]	Benennung - Title Werkzeugaufnahme Tool adaptor	EWS Werkzeug-Gesellschaft & Co. KG Hauptstr. 1 62700 Limburg www.ews-tool.de Technische Änderungen vorbehalten! Subject to technical modifications! IDENT: DEWS265396	Nr. - No. 19.BMTABS100SL603Z50 HNB. REV. - /JB 232066
----------------------	--	---	---	---

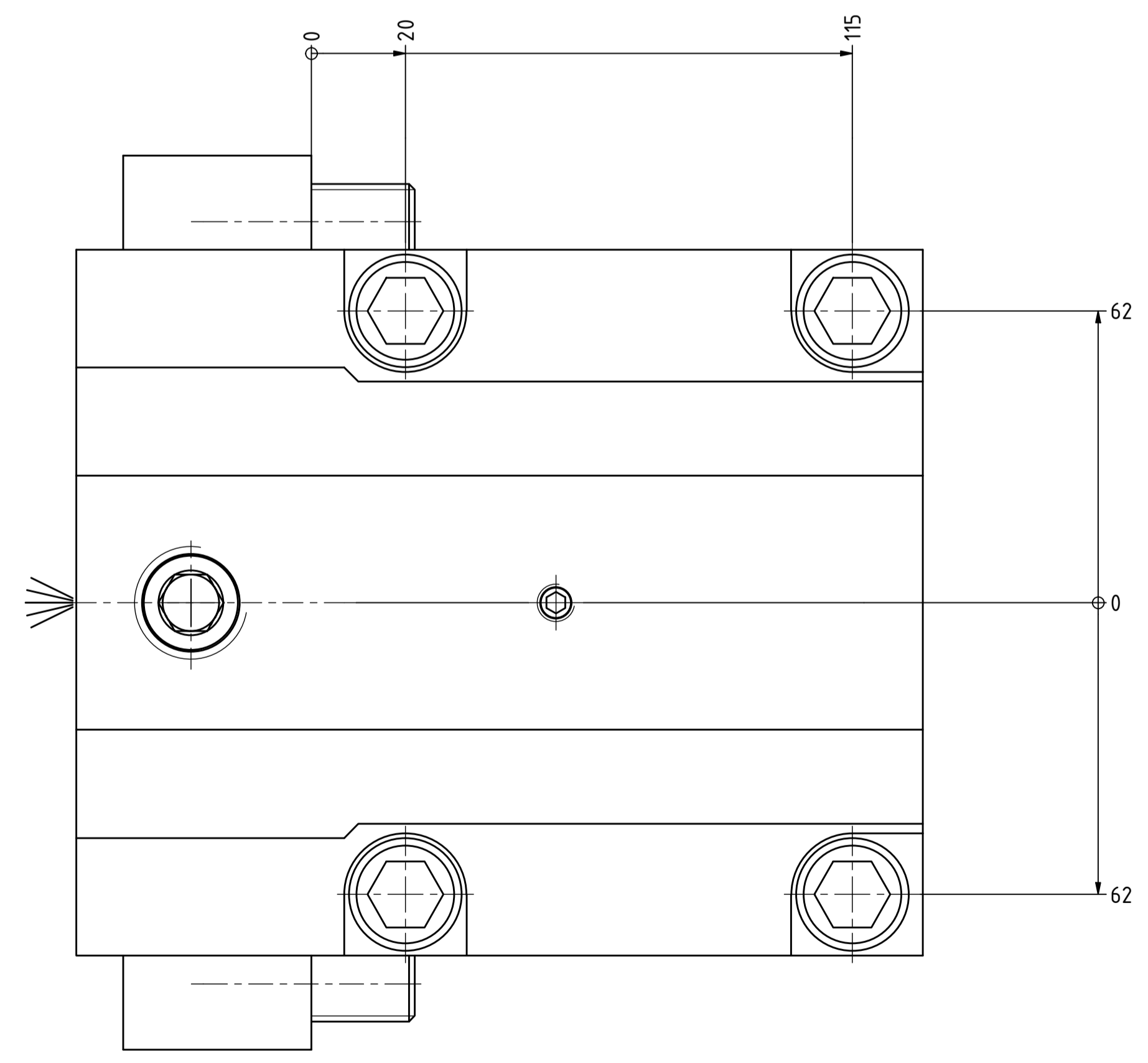
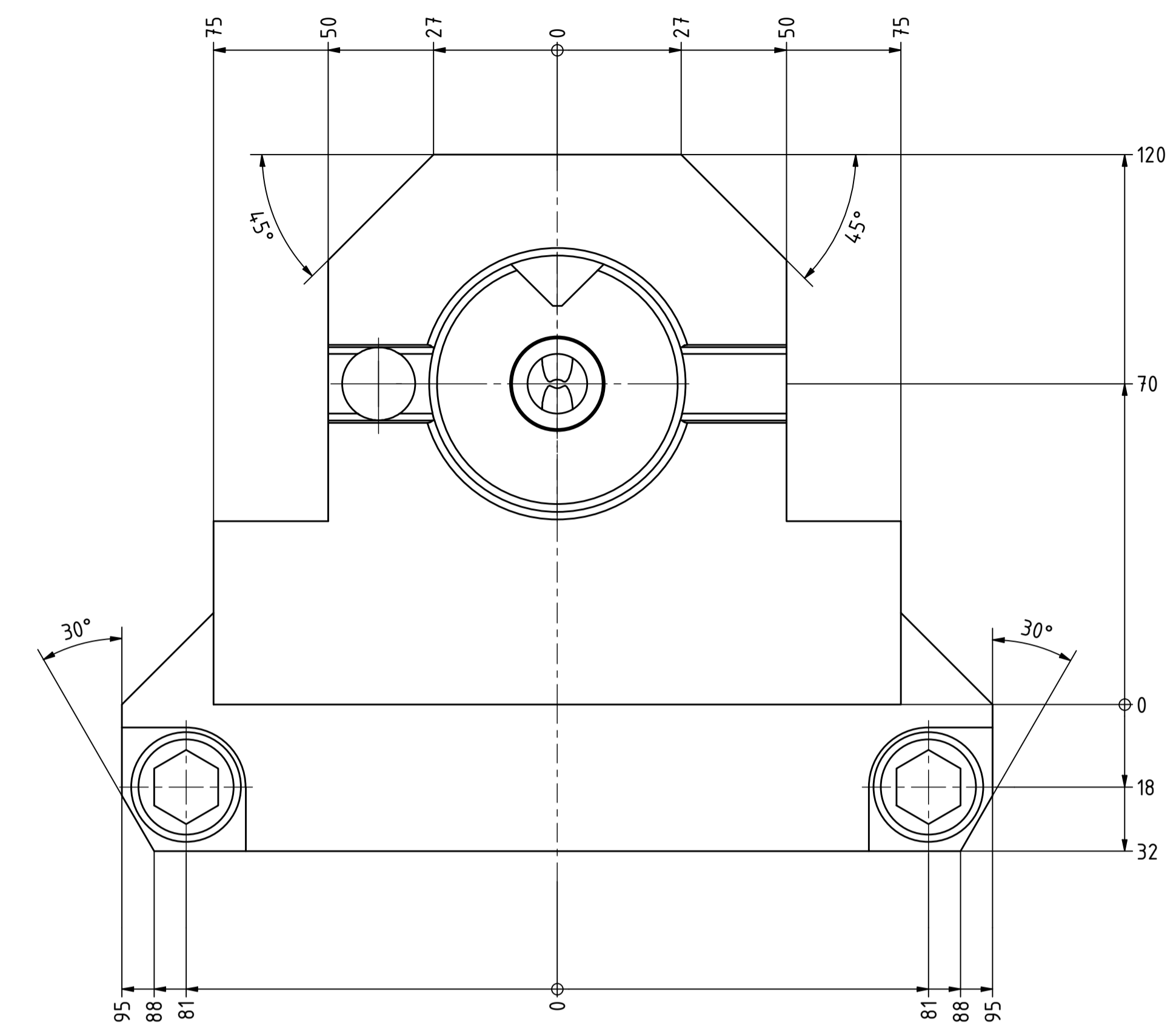
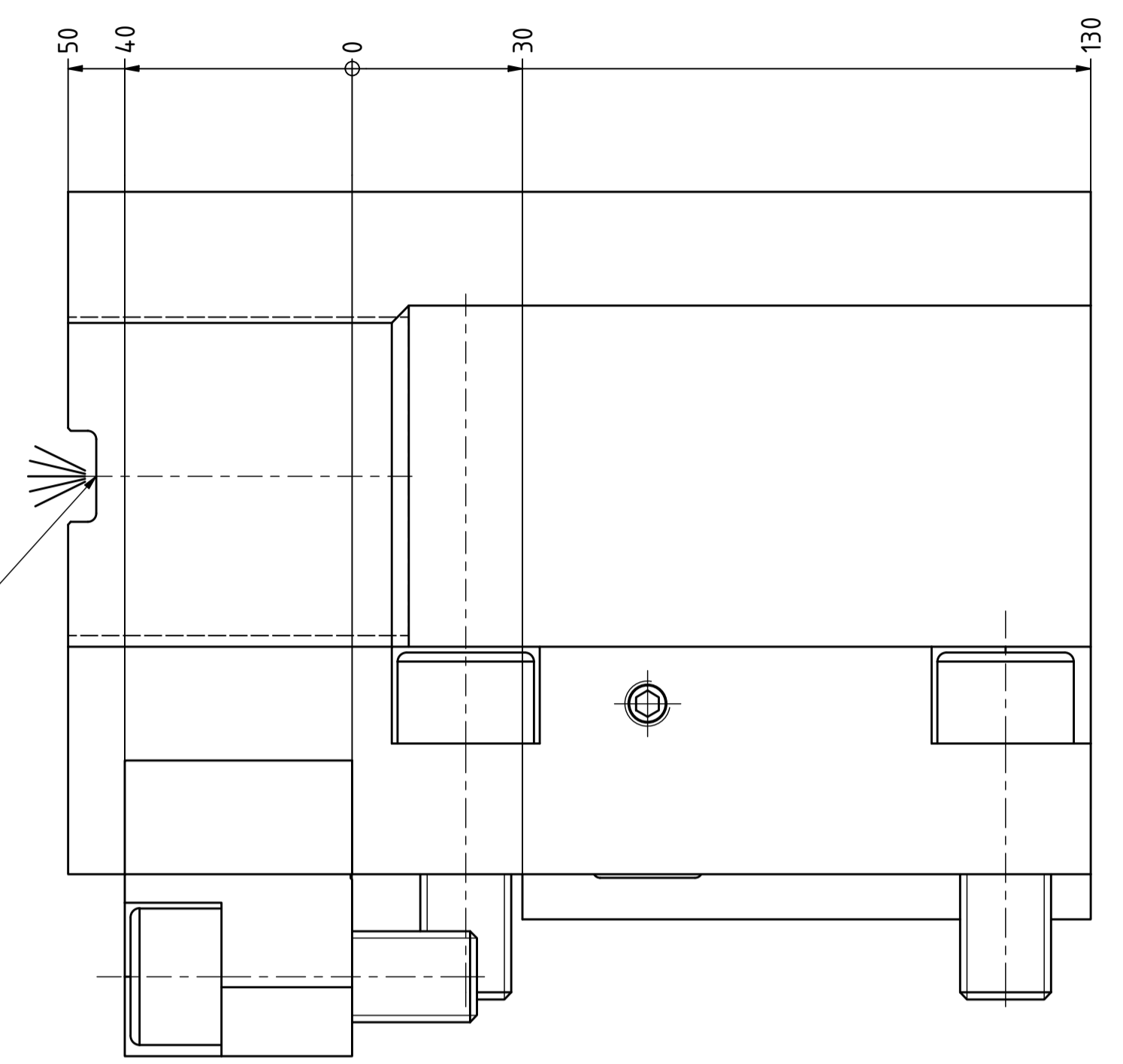