

Polygon ISO 26623 PSC 40

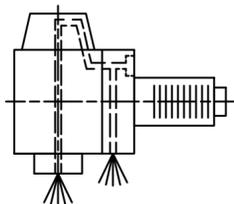
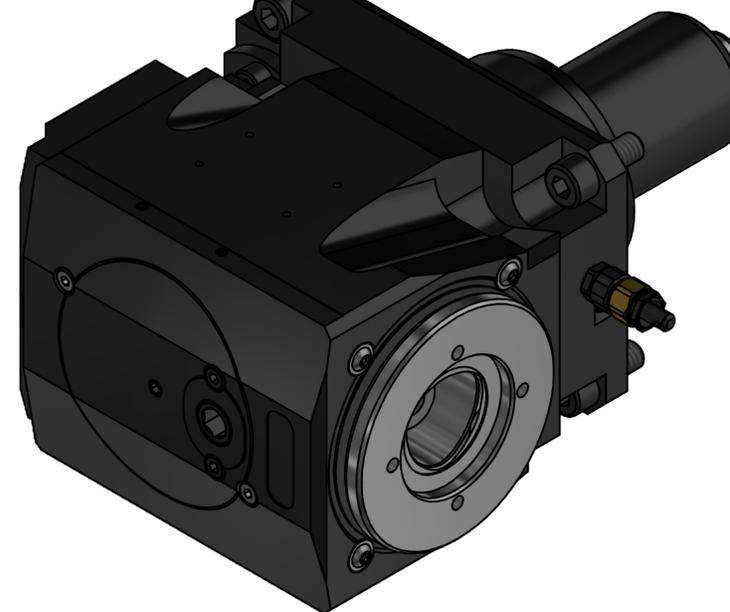

Innen- und Auskühlung / Inside and outside coolant supply
Kühlmittelfiltrierung-50µ / coolant filtration-50µ

Copyright **EWS Tool Technologies**
Weitergabe und Vervielfältigung dieser Unterlage,
Verwertung und Mitteilung ihres Inhalts nicht
gestattet, soweit nicht ausdrücklich zugestanden.
Zuwendungen verpflichten zu Schadenersatz.

<p>Bemerkung - Note Für Trockenlauf geeignet! Use without coolant fluid allowed!</p>	<p>Technische Daten - technical data Weight = 9.307 [kg] Torque max. (M1/M2) = 63 / 63 [Nm] Speed max. (n1/n2) = 6000 / 6000 [1/min] Gear ratio (i)=n1:n2 = 1:1 Pressure (pmax) = 70 [bar]</p>	<p>Benennung - Title</p>	<p>EWS Tool Technologies EWS Weigle GmbH & Co. KG Maybachstr. 1 D-73066 Ulm/ingen www.ews-tool.de</p>	<p>Technische Änderungen vorbehalten! Subject to technical modifications! IDENT: DEWS262725</p>	<p>REV: -/A MNR. 232246</p>	<p>QR</p>
--	--	--------------------------	--	---	-------------------------------------	-----------

60.68C4QSMBMTIKD