

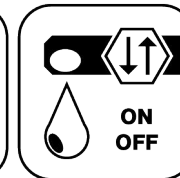

Ceramic Seal



Butterfly Seal



Coolant Management



Tech Details

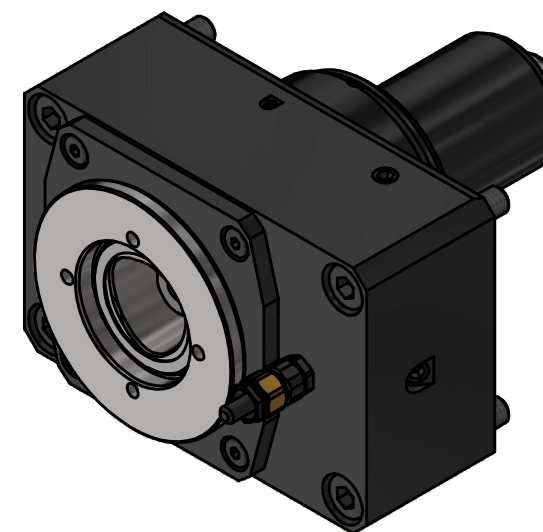
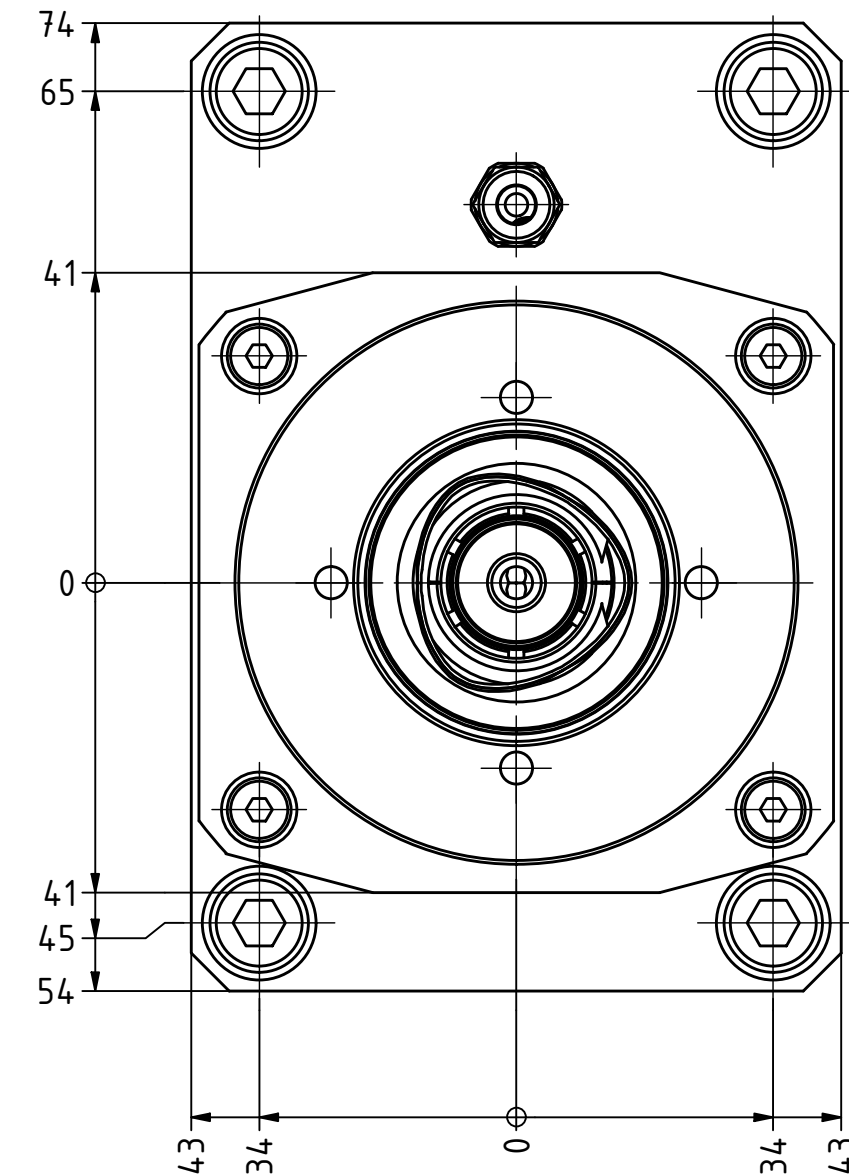
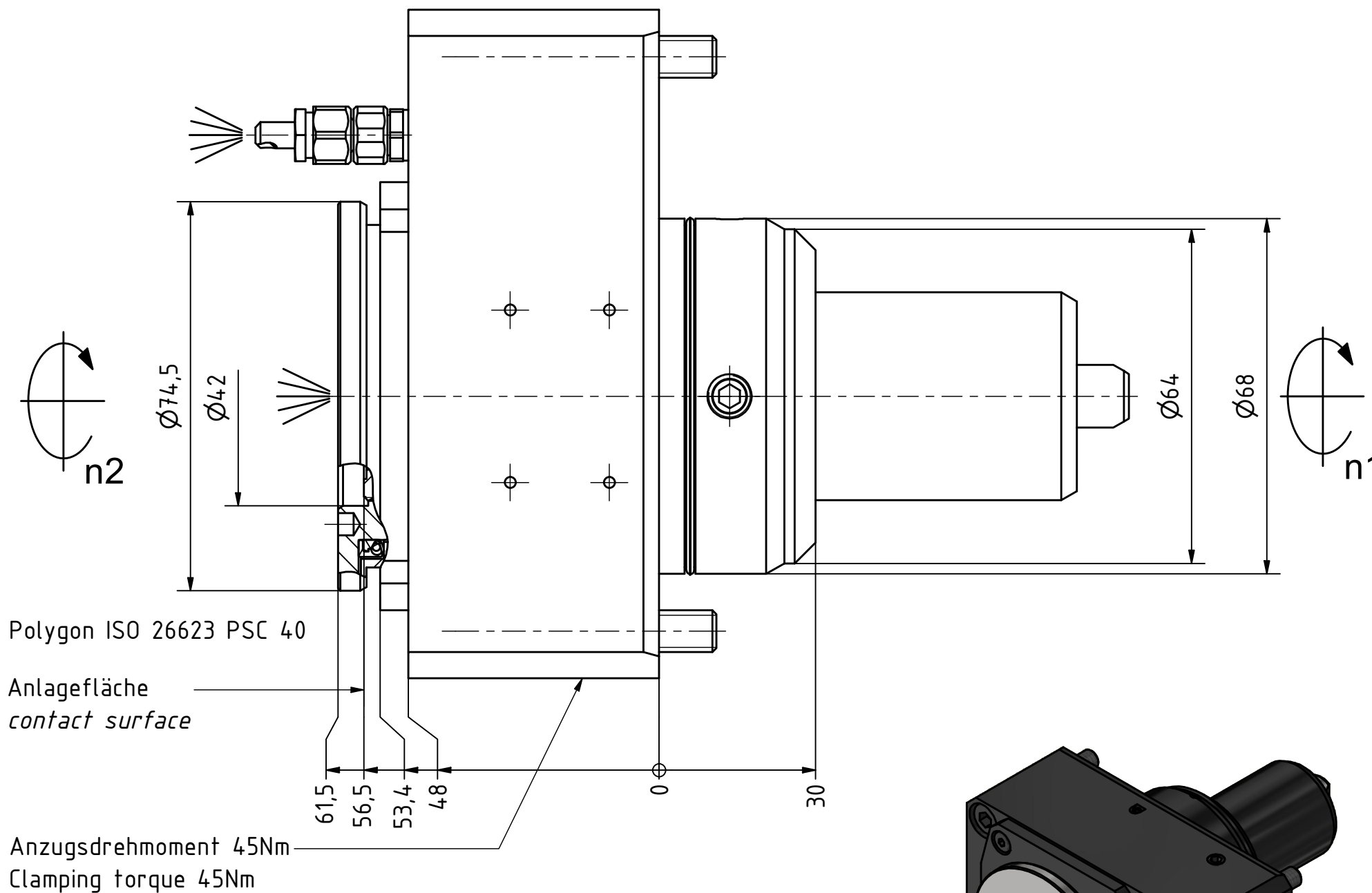

Innen- und Aussenkuehlung / Inside and outside coolant supply
Kuehlmittelfiltrierung-50 μ / coolant filtration-50 μ

Copyright **EWS Tool Technologies**
Weitergabe und Vervielfaeltigung dieser Unterlage,
Verwertung und Mitteilung ihres Inhalts nicht
gestattet, soweit nicht ausdrucklich zugestanden.
Zuwiderhandlungen verpflichten zu Schadenersatz.

Bemerkung - Note
Für Trockenlauf geeignet!
Use without coolant fluid allowed!

Technische Daten - technical data
Weight = 5.236 [kg]
Torque max. (M1/M2) = 63 / 63 [Nm]
Speed max. (n1/n2) = 6000 / 6000 [1/min]
Gear ratio (i)=n1:n2 = 1:1
Pressure (pmax) = 70 [bar]

Benennung - Title
Axial Bohr und Fräskopf
Axial drilling and milling head

EWS
Tool Technologies
EWS Weigle GmbH & Co. KG
Maybachstr. 1
D-73066 Uthingen
www.ews-tools.de

Technische Aenderungen vorbehalten!
Subject to technical modifications!

IDENT: DEWS262703



REV: -/A

Nr. - No.
40.68C4QSMBMTIKC

MNR.
232244

QR