

Doppelverzahnung Lizenz Traub
double tooth system licence Traub

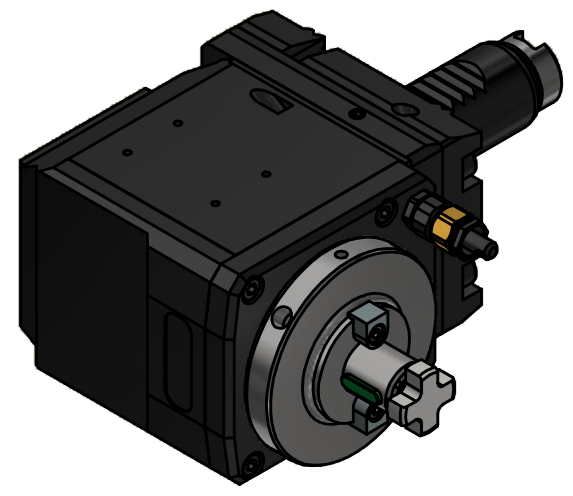

Copyright **EWS Tool Technologies**
Weitergabe und Vervielfaeltigung dieser Unterlage,
Verwertung und Mitteilung ihres Inhalts nicht
gestattet, soweit nicht ausdrecklich zugestanden.
Zuwiderhandlungen verpflichten zu Schadenersatz.

Bemerkung - Note
mit Kegelrollenlager
with taper roller bearing(s)

Technische Daten - technical data
Weight = 4.111 [kg]
Torque max. (M1/M2) = 25 / 25 [Nm]
Speed max. (n1/n2) = 5000 / 5000 [1/min]
Gear ratio (i)=n1:n2 = 1:1

Benennung - Title
Radial Fräskopf
Radial milling head

EWS Tool Technologies
EWS Weigele GmbH & Co. KG
Maybachstr. 1
D-73066 Uthingen
www.ews-tools.de

Technische Aenderungen vorbehalten!
Subject to technical modifications!
IDENT: DEWS264870
REV: -/A
MNR.
232210

Nr. - No.
62.2516KRG200RLW#01

