

Spannzange / collet ER25 DIN6499
Spannbereich / clamping range: 1,0 - 16,0

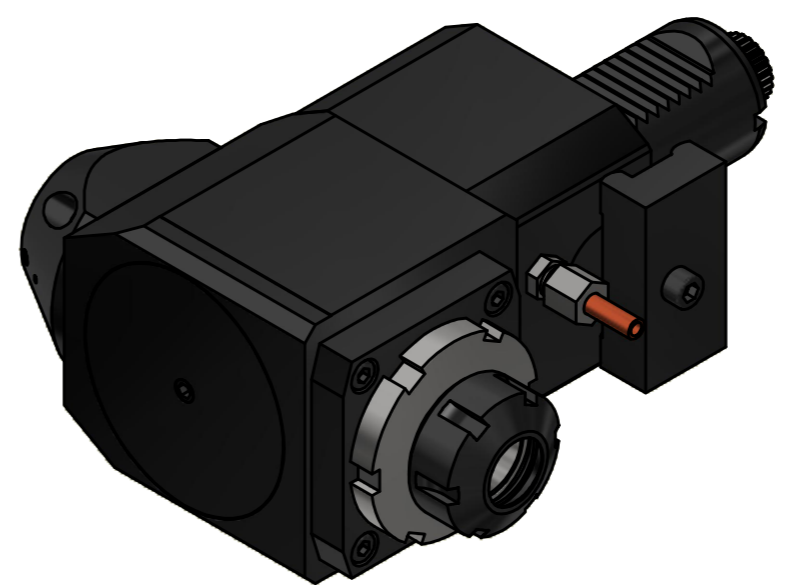

Hakenschlüssel
mit Nase
Hook wrench with
nose end
DIN1810 A 58x62

Spannzangenschlüssel
Clamping wrench
225

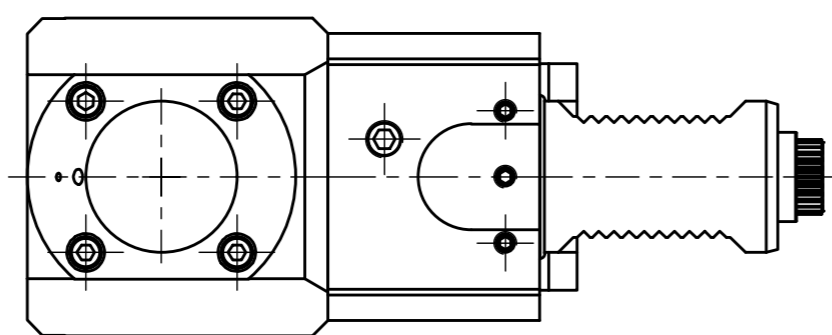

Doppelverzahnung Lizenz Traub
double tooth system licence Traub

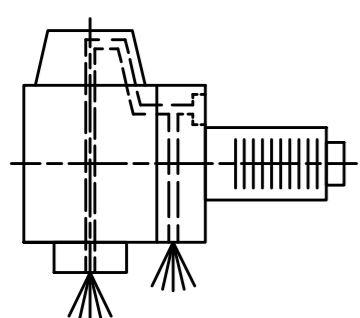

Innen- und Aussenkuehlung / Inside and outside coolant supply
Kein Trockenlauf / No dry run
Kuehlmittelfiltrierung=50µ / coolant filtration=50µ

Copyright **EWS Tool Technologies**
Weitergabe und Vervielfaeltigung dieser Unterlage,
Verwertung und Mitteilung ihres Inhalts nicht
gestattet, soweit nicht ausdrecklich zugestanden.
Zuwaerhandlungen verpflichten zu Schadenersatz.

Bemerkung - Note Nicht ohne Kuehlmittel betreiben! Not for use without coolant-fluid!	Technische Daten - technical data Weight = 7.130 [kg]
	Torque max. (M1/M2) = 45 / 15 [Nm]
	Speed max. (n1/n2) = 5000 / 15000 [1/min]
	Gear ratio (i)=n1:n2 = 1:3
	Pressure (pmax) = 70 [bar]

Benennung - Title
Radial Bohr und Fräskopf
Radial drilling and milling head

EWS <small>Tool Technologies</small> EWS Weigle GmbH & Co. KG Maybachstr. 1 D-73066 Uhlingen www.ews-tool.de	Technische Aenderungen vorbehalten! Subject to technical modifications! IDENT: DEWS262377	
	Nr. - No. 60.4025CTXRLIK1130T26	REV: -/A MNR. 232131