

Spannzange / collet ER25 DIN6499
Spannbereich / clamping range: 1,0 - 16,0

Gewindebohrzange / tapping collet
ET-1-25 M3-M12

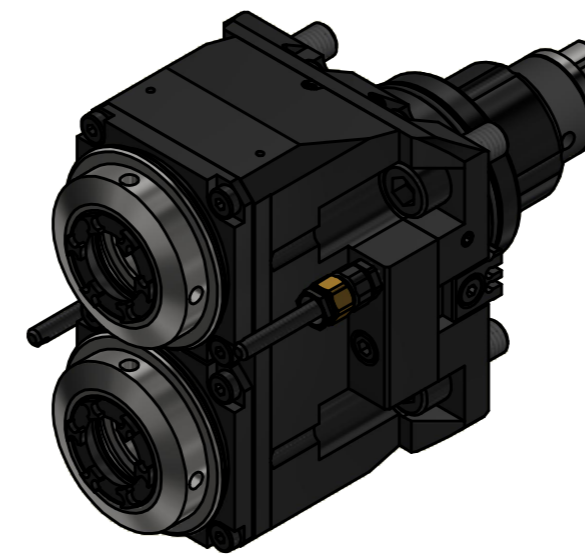
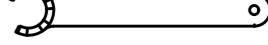

Hakenschlüssel
mit Zapfen
Hook wrench
with fixed pin
DIN1810 B 45x50

Spannzangenschlüssel für
innenliegende Mutter
Clamping wrench for
internal collet
225AX

Copyright **EWS Tool Technologies**
Weitergabe und Vervielfältigung dieser Unterlage,
Verwertung und Mitteilung ihres Inhalts nicht
gestattet, soweit nicht ausdrücklich zugestanden.
Zuwerhandlungen verpflichten zu Schadenersatz.

Bemerkung - Note

Technische Daten - technical data

Weight = 6,013 [kg]
Torque max. (M1/M2) = 25 / 12,5 | 12,5 [Nm]
Speed max. (n1/n2) = 6000 / 6000 | 6000 [1/min]
Gear ratio (i)=n1:n2 = 1:1 | 1:1

Benennung - Title

Axial Bohr und Fräskopf
Axial drilling and milling head



Nr. - No.
40.5525DYVL2FIMTK60

Technische Änderungen vorbehalten!
Subject to technical modifications!
IDENT: DEWS265722

REV: -/A
MNR.
231960

