

Doppelverzahnung Lizenz Traub  
 double tooth system licence Traub

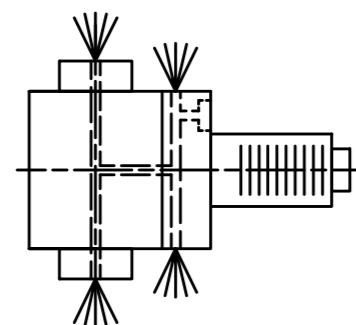

Innen- und Aussenkuehlung / Inside and outside coolant supply  
 Kuehlmittelfiltrierung+50µ / coolant filtration+50µ

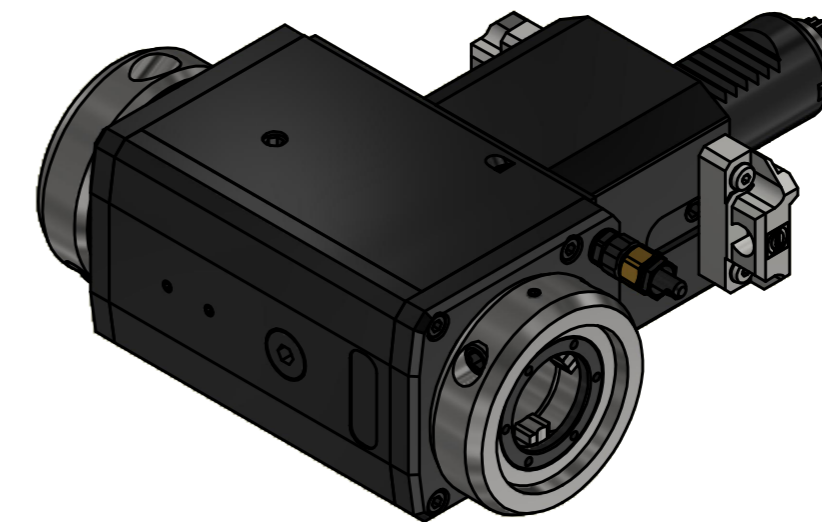

Copyright **EWS Tool Technologies**  
 Weitergabe und Vervielfaeltigung dieser Unterlage,  
 Verwertung und Mitteilung ihres Inhalts nicht  
 gestattet, soweit nicht ausdrecklich zugestanden.  
 Zuwiderhandlungen verpflichten zu Schadenersatz.

Bemerkung - Note Für Trockenlauf geeignet! Use without coolant fluid allowed!	Technische Daten - technical data Weight = 6.672 [kg] Torque max. (M1/M2) = 32 / 32   32 [Nm] Speed max. (n1/n2) = 12000 / 12000   12000 [1/min] Gear ratio (i)=n1:n2 = 1:1   1:1 Pressure (pmax) = 70 [bar]	Benennung - Title <b>Radial Bohr und Fräskopf</b> <b>Radial drilling and milling head</b>	<table border="1"> <tr> <td data-bbox="2226 1917 2463 1984"> <b>EWS</b>  <small>EWS Weigle GmbH &amp; Co. KG            Maybachstr. 1            D-73066 Uhlingen            www.ews-tools.de</small> </td> <td data-bbox="2463 1917 2700 1984">           Technische Aenderungen vorbehalten!            Subject to technical modifications!            IDENT: DEWS261160         </td> <td data-bbox="2700 1917 2908 1984">             REV: -/A         </td> </tr> <tr> <td data-bbox="2226 1984 2463 2047">           Nr. - No.  <b>60.30VX3LDCTXRLIKCTFRHSD12</b> </td> <td data-bbox="2463 1984 2700 2047">           MNR.  <b>231908</b> </td> <td data-bbox="2700 1984 2908 2047"> <b>QR</b> </td> </tr> </table>	<b>EWS</b> <small>EWS Weigle GmbH &amp; Co. KG            Maybachstr. 1            D-73066 Uhlingen            www.ews-tools.de</small>	Technische Aenderungen vorbehalten! Subject to technical modifications! IDENT: DEWS261160	 REV: -/A	Nr. - No. <b>60.30VX3LDCTXRLIKCTFRHSD12</b>	MNR. <b>231908</b>	<b>QR</b>
<b>EWS</b> <small>EWS Weigle GmbH &amp; Co. KG            Maybachstr. 1            D-73066 Uhlingen            www.ews-tools.de</small>	Technische Aenderungen vorbehalten! Subject to technical modifications! IDENT: DEWS261160	 REV: -/A							
Nr. - No. <b>60.30VX3LDCTXRLIKCTFRHSD12</b>	MNR. <b>231908</b>	<b>QR</b>							