

Doppelverzahnung Lizenz Traub  
double tooth system licence Traub

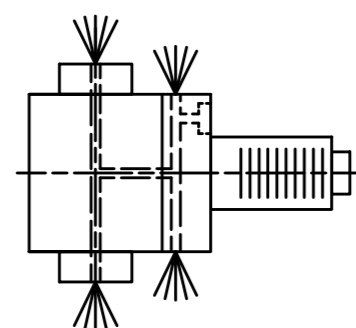
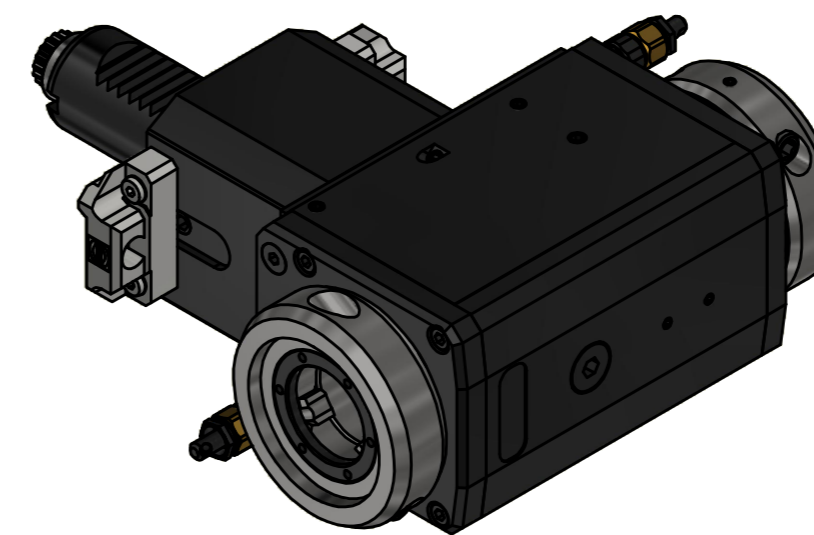

Innen- und Aussenkuehlung / Inside and outside coolant supply  
Kuehlmittelfiltrierung<50µ / coolant filtration<50µ

Bemerkung - Note  
 Für Trockenlauf geeignet!  
 Use without coolant fluid allowed!

Technische Daten - technical data	
Weight	= 6.672 [kg]
Torque max. (M1/M2)	= 32 / 32   32 [Nm]
Speed max. (n1/n2)	= 12000 / 12000   12000 [1/min]
Gear ratio (i)=n1:n2	= 1:1   1:1
Pressure (pmax)	= 70 [bar]

Benennung - Title  
**Radial Bohr und Fräskopf**  
**Radial drilling and milling head**

<b>EWS</b> <small>Tool Technologies</small> <small>EWS Weigle GmbH &amp; Co. KG          Maybachstr. 1          D-73066 Uhlingen          www.ews-tool.de</small>	<small>Technische Änderungen vorbehalten!</small> <small>Subject to technical modifications!</small> IDENT: DEWS261167	<small>REV: -/A</small>
	Nr. - No. <b>60.30VX3LDCTXRLIKCTFLHSD12</b>	MNR. <b>231907</b>



Copyright **EWS Tool Technologies**  
 Weitergabe und Vervielfältigung dieser Unterlage,  
 Verwertung und Mitteilung ihres Inhalts nicht  
 gestattet, soweit nicht ausdrücklich zugestanden.  
 Zuwiderhandlungen verpflichten zu Schadenersatz.