

Spannzangenschlüssel für  
innenliegende Mutter  
Clamping wrench for  
internal collet  
225AX

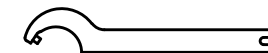

Hakenschlüssel  
mit Zapfen  
Hook wrench  
with fixed pin  
DIN1810 B 58x62



Butterfly  
Seal

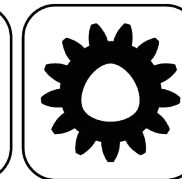

Polygon  
Joint

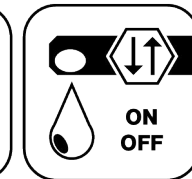

Coolant  
Management



Tech  
Details

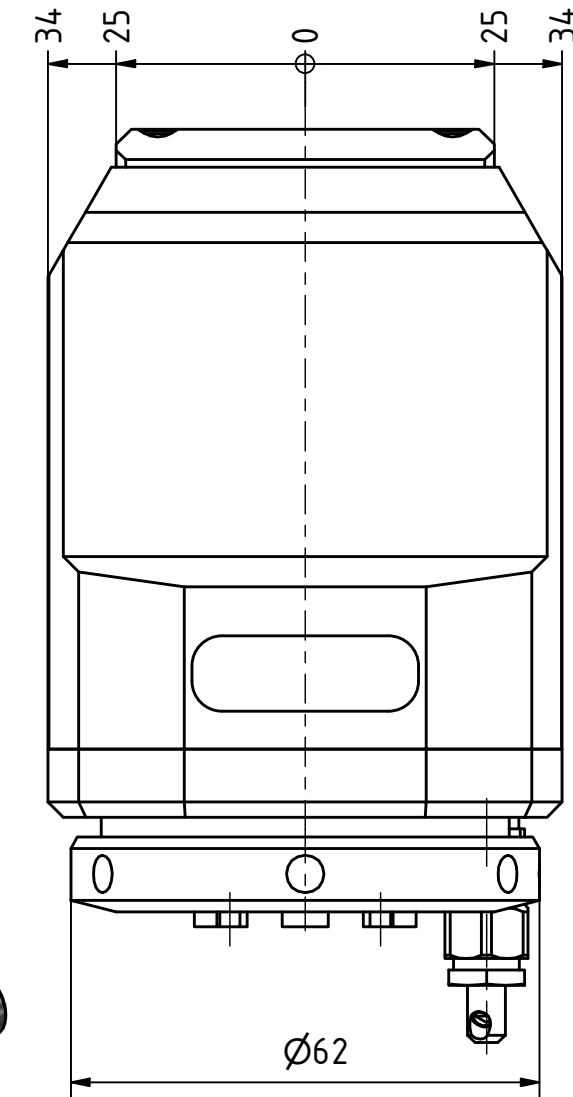
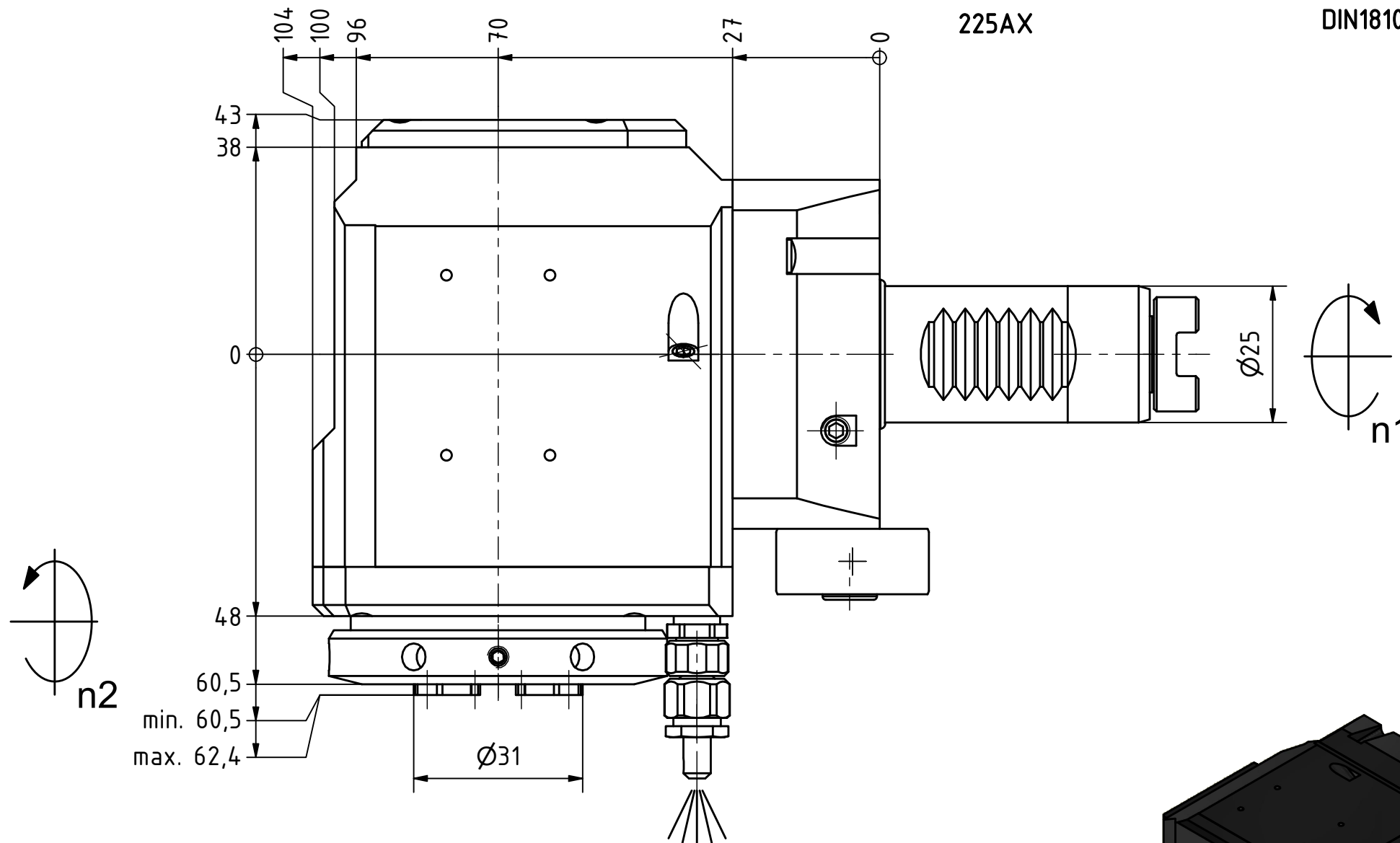

Spannzange / collet ER25 DIN6499  
Spannbereich / clamping range: 1,0 - 16,0

Gewindebohrzange / tapping collet  
ET-1-25 M3-M12

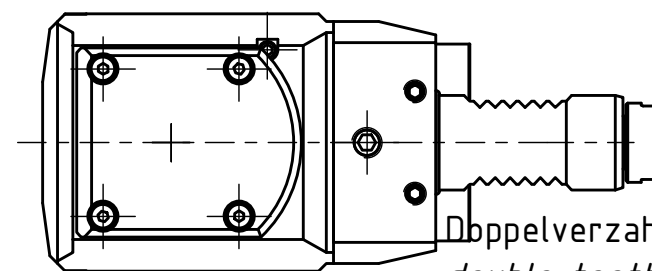

Doppelverzahnung Lizenz Traub  
double tooth system licence Traub

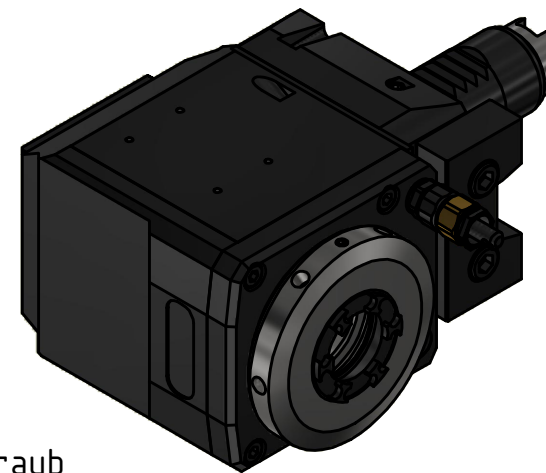

Copyright **EWS Tool Technologies**  
Weitergabe und Vervielfältigung dieser Unterlage,  
Verwertung und Mitteilung ihres Inhalts nicht  
gestattet, soweit nicht ausdrücklich zugestanden.  
Zuwendungen verpflichten zu Schadenersatz.

Bemerkung - Note

mit Kegelrollenlager  
with taper roller bearing(s)

Technische Daten - technical data

Weight = 3.804 [kg]  
Torque max. (M1/M2) = 25 / 25 [Nm]  
Speed max. (n1/n2) = 5000 / 5000 [1/min]  
Gear ratio (i)=n1:n2 = 1:1

Benennung - Title

Radial Bohr und Fräskopf  
Radial drilling and milling head

**EWS**  
Tool Technologies

Nr. - No.

60.2525KRG200RLVIM#01

EWS Weigele GmbH & Co. KG  
Maybachstr. 1  
D-73066 Uthingen  
www.ews-tools.de

Technische Änderungen vorbehalten!  
Subject to technical modifications!

IDENT: DEWS260758

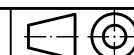

REV: -/A

MNR.

231822

QR