

W-Verzahnung Lizenz Index-Werke  
W-tooth system licence Index-Corporation

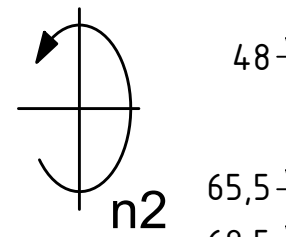

Anlagefläche  
contact surface

EWS-Varia VX3

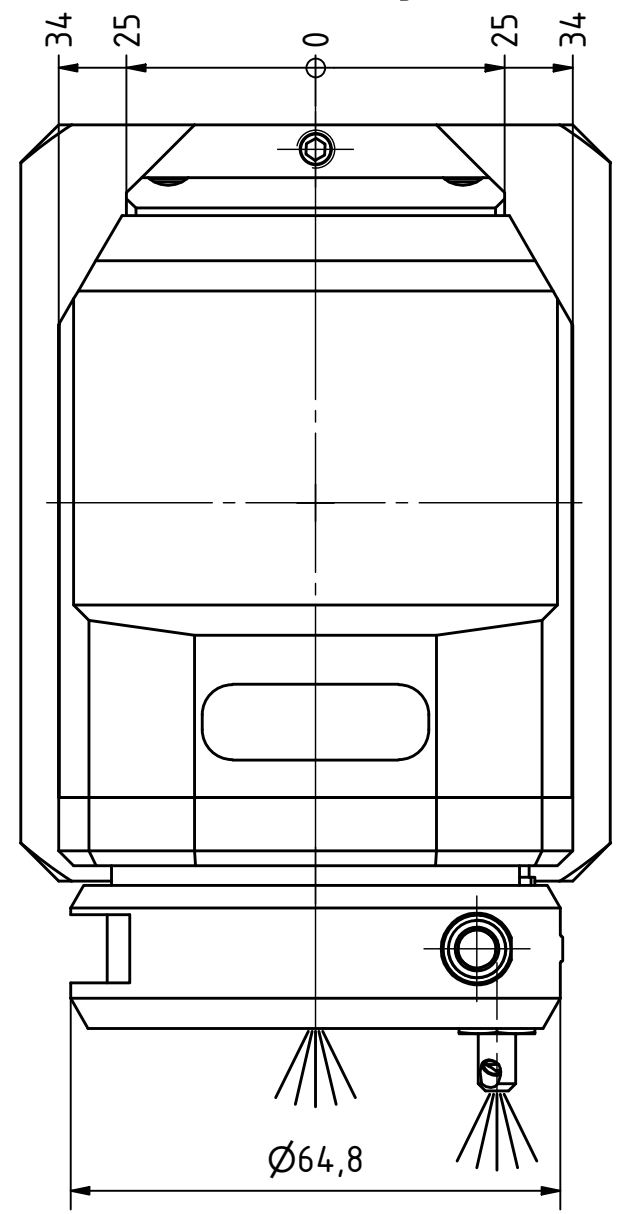
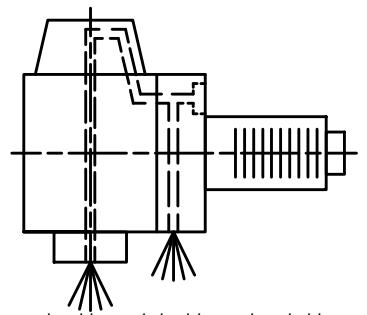

Innen- und Aussenkuehlung / Inside and outside coolant supply  
Kuehlmittelfiltrierung<50µ / coolant filtration<50µ

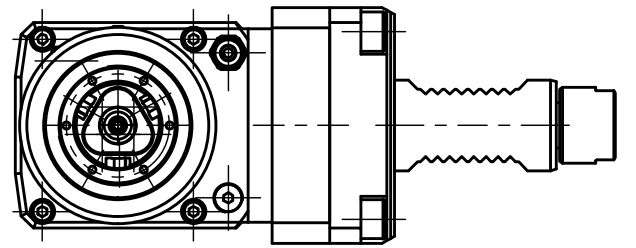

Doppelverzahnung Lizenz Traub  
double tooth system licence Traub

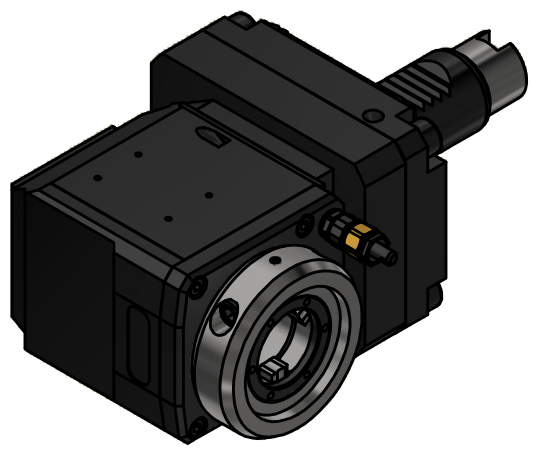

Copyright **EWS Tool Technologies**  
Weitergabe und Vervielfaeltigung dieser Unterlage,  
Verwertung und Mitteilung ihres Inhalts nicht  
gestattet, soweit nicht ausdrecklich zugestanden.  
Zuwiderhandlungen verpflichten zu Schadenersatz.

Bemerkung - Note  
Für Trockenlauf geeignet!  
Use without coolant fluid allowed!  
mit Kegelrollenlager  
with taper roller bearing(s)

Technische Daten - technical data	
Weight	= 5.758 [kg]
Torque max. (M1/M2)	= 32 / 32 [Nm]
Speed max. (n1/n2)	= 5000 / 5000 [1/min]
Gear ratio (i)=n1:n2	= 1:1
Pressure (pmax)	= 70 [bar]

Benennung - Title  
**Radial Bohr und Fräskopf**  
**Radial drilling and milling head**

**EWS** Tool Technologies  
EWS Weigele GmbH & Co. KG  
Maybachstr. 1  
D-73066 Uthingen  
www.ews-tools.de

Technische Aenderungen vorbehalten! Subject to technical modifications!	
IDENT: DEWS260602	REV: -/A
Nr. - No.	MNR.
<b>60.30VX3KRG300RLIKDW</b>	<b>231782</b>

