

n2 Spannzange / collet ER32 DIN6499
Spannbereich / clamping range: 2,0 - 20,0

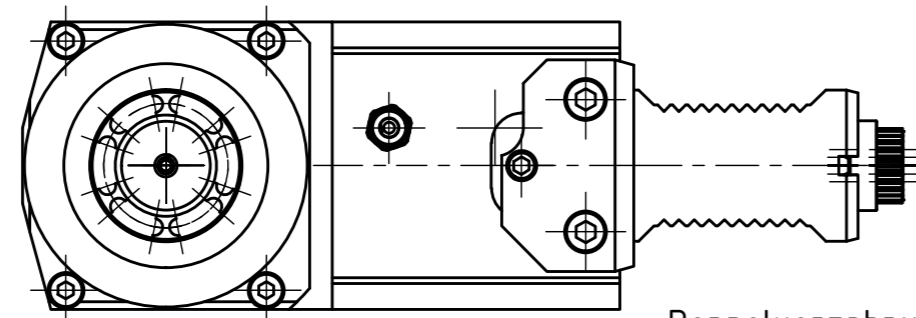

Doppelverzahnung Lizenz Traub
double tooth system licence Traub

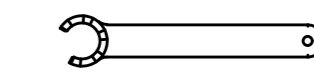
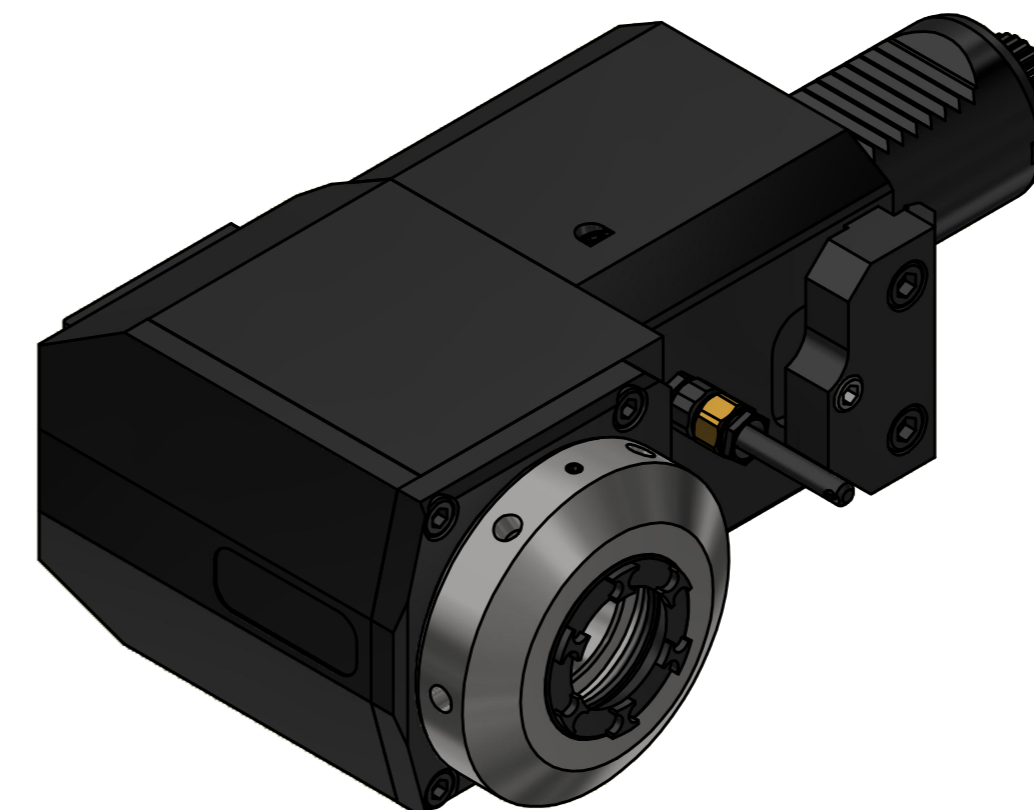

Spannzangenschlüssel für innenliegende Mutter
Clamping wrench for internal collet
232AX

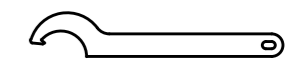

Hakenschlüssel mit Nase
Hook wrench with nose end
DIN1810 A 68x75

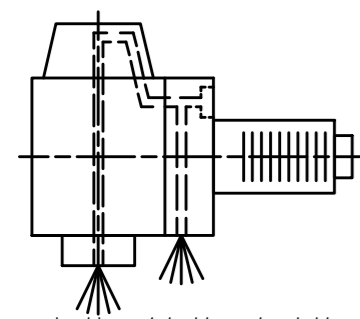

Innen- und Aussenkuehlung / Inside and outside coolant supply
Kuehlmittelfiltrierung 50μ / coolant filtration 50μ

Copyright **EWS Tool Technologies**
Weitergabe und Vervielfaeltigung dieser Unterlage,
Verwertung und Mitteilung ihres Inhalts nicht
gestattet, soweit nicht ausdrecklich zugestanden.
Zuwiderhandlungen verpflichten zu Schadenersatz.

<p>Bemerkung - Note Für Trockenlauf geeignet! Use without coolant fluid allowed!</p>	<p>Technische Daten - technical data Weight = 7.886 [kg] Torque max. (M1/M2) = 50 / 25 [Nm] Speed max. (n1/n2) = 6000 / 12000 [1/min] Gear ratio (i)=n1:n2 = 1:2 Pressure (pmax) = 70 [bar]</p>	<p>Benennung - Title Radial Bohr und Fräskopf Radial drilling and milling head</p>	<p>EWS Tool Technologies EWS Weigle GmbH & Co. KG Maybachstr. 1 D-73066 Uhlingen www.ews-tool.de</p> <p>Technische Aenderungen vorbehalten! Subject to technical modifications! IDENT: DEWS260499</p> <p>Nr. - No. 60.4032E365RLIKD11MX120</p> <p>REV: -/A MNR. 231740</p> <p>QR</p>
--	---	--	--