

Spannzange / collet ER32 DIN6499
 Spannbereich / clamping range: 2,0 - 20,0

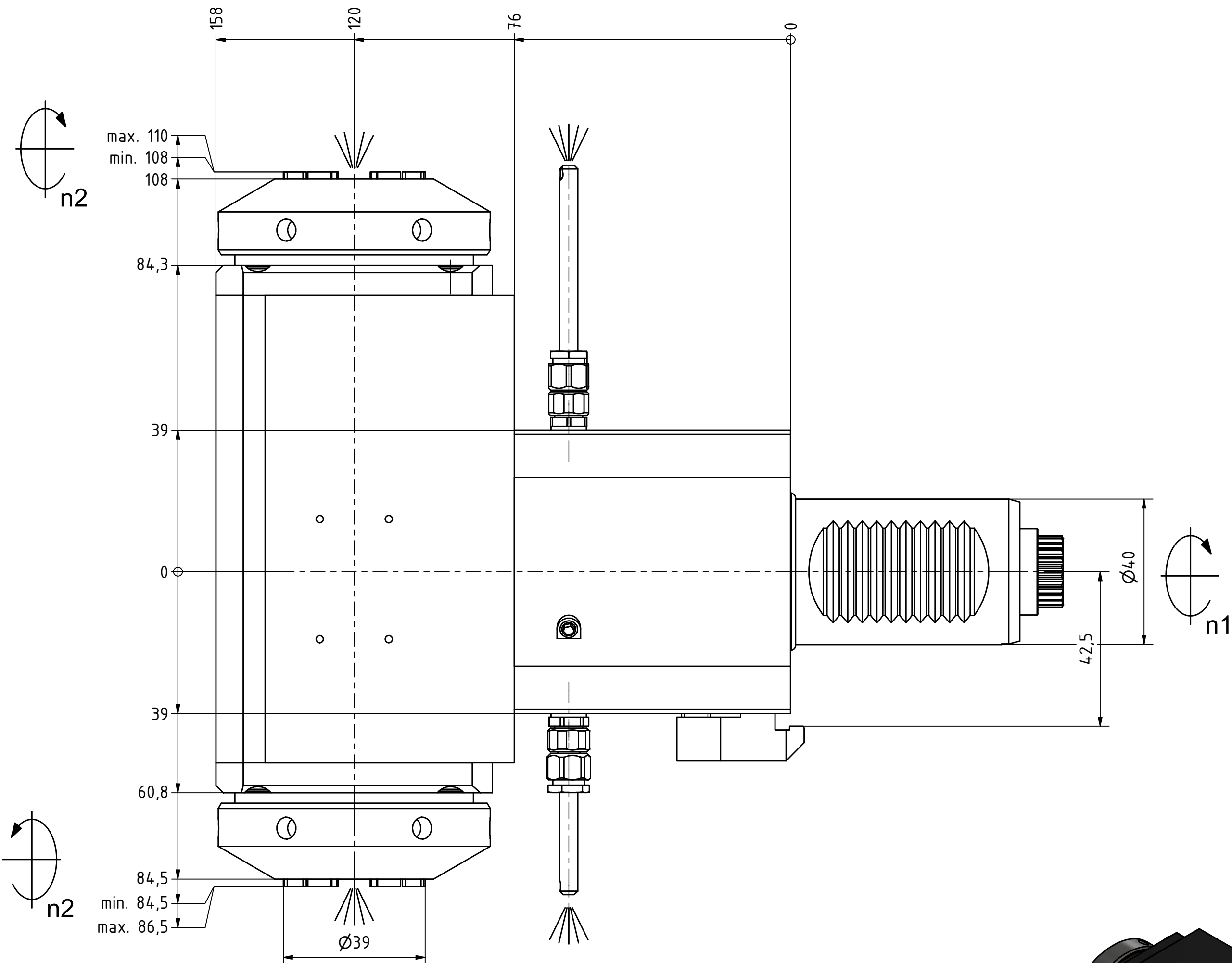

Spannzange / collet ER32 DIN6499
 Spannbereich / clamping range: 2,0 - 20,0

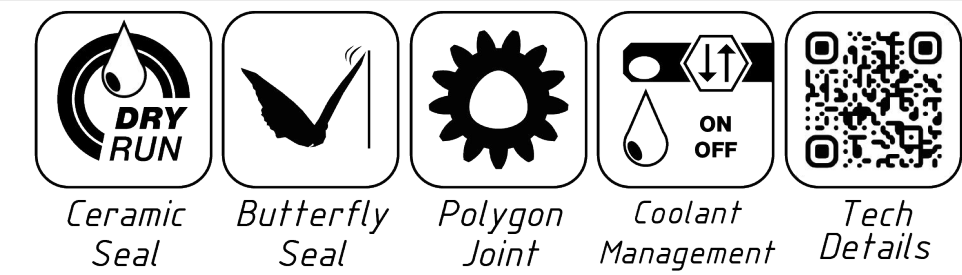
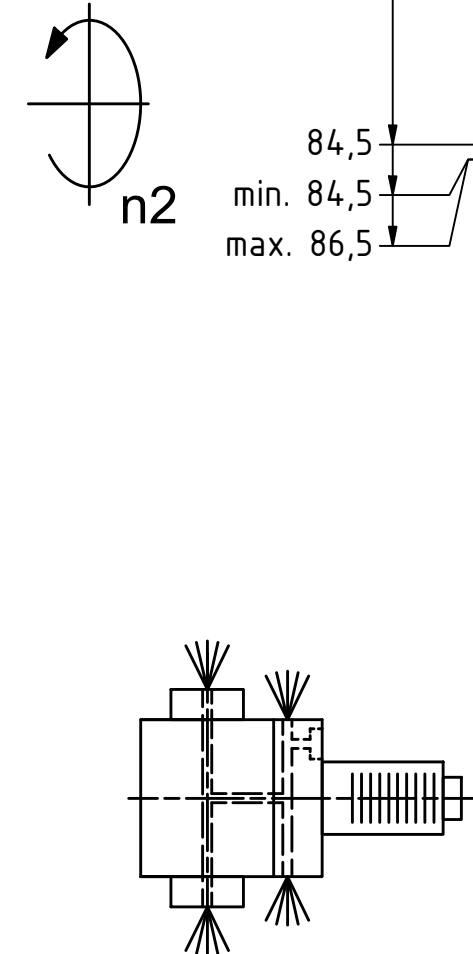
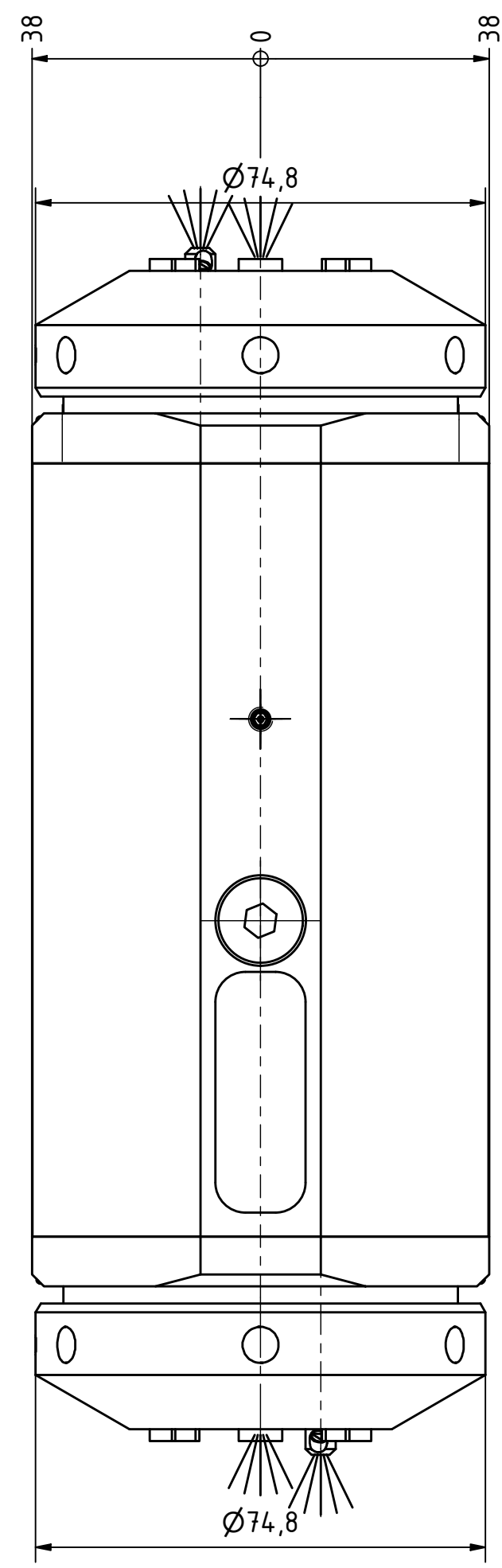

Innen- und Aussenkuehlung / Inside and outside coolant supply
 Kuehlmittelfiltrierung=50µ / coolant filtration=50µ

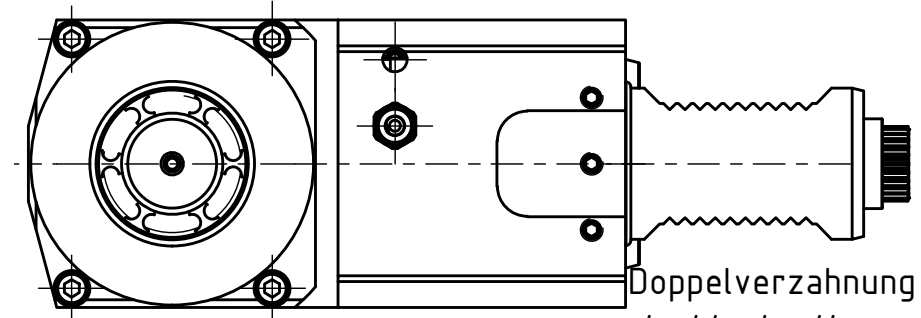

Doppelverzahnung Lizenz Traub
 double tooth system licence Traub

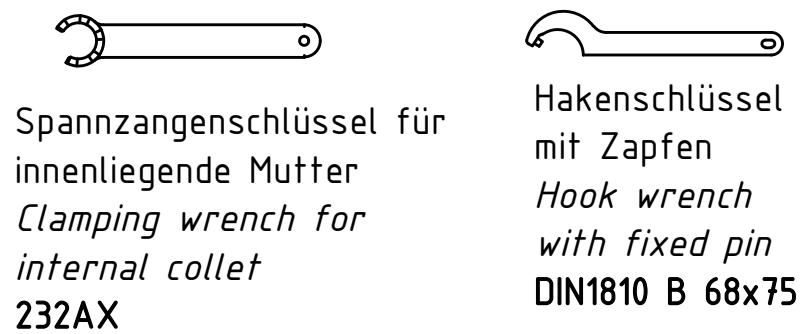
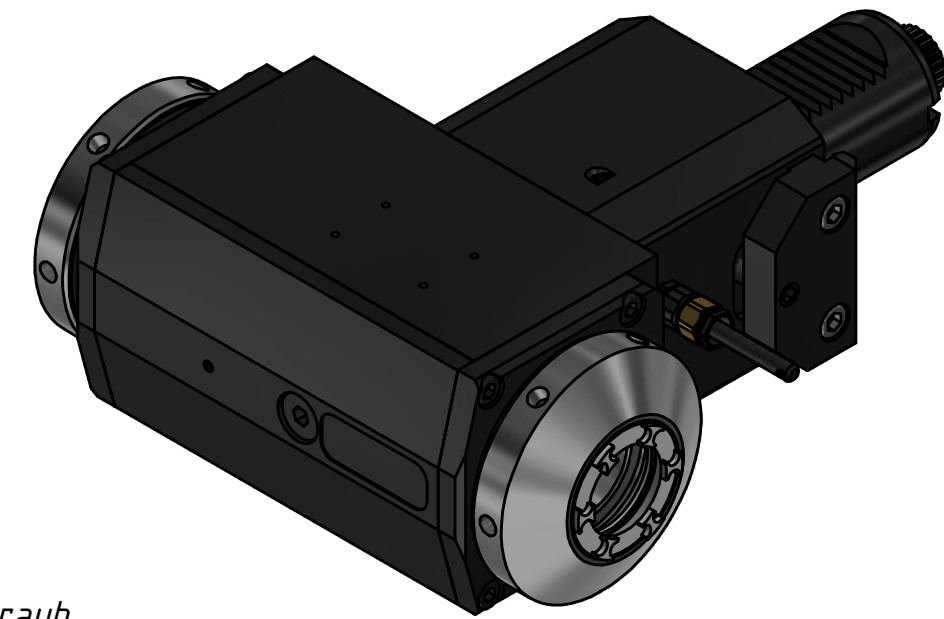

Spannzangenschlüssel für innenliegende Mutter
 Clamping wrench for internal collet
 232AX

Hakenschlüssel mit Zapfen
 Hook wrench with fixed pin
 DIN1810 B 68x75

Copyright EWS Tool Technologies
 Weitergabe und Vervielfaeltigung dieser Unterlage, Verwertung und Mitteilung ihres Inhalts nicht gestattet, soweit nicht ausdrecklich zugestanden. Zuwiderhandlungen verpflichten zu Schadenersatz.

Bemerkung - Note Für Trockenlauf geeignet! Use without coolant fluid allowed!	Technische Daten - technical data Weight = 10.399 [kg]
	Torque max. (M1/M2) = 63 / 63 63 [Nm]
	Speed max. (n1/n2) = 6000 / 6000 6000 [1/min]
	Gear ratio (i)=n1:n2 = 1:1 1:1
	Pressure (pmax) = 70 [bar]

Benennung - Title
Radial Bohr und Fräskopf
Radial drilling and milling head

EWS Tool Technologies Nr. - No. 60.4032DE365RLIKDIMX120	EWS Weigle GmbH & Co. KG Maybachstr. 1 D-73066 Ulm/ingen www.ews-tools.de	Technische Aenderungen vorbehalten! Subject to technical modifications! IDENT: DEWS260524	MNR. REV: -/A 231737
	QR		