

Spannzange / collet ER32 DIN6499
 Spannbereich / clamping range: 2,0 - 20,0

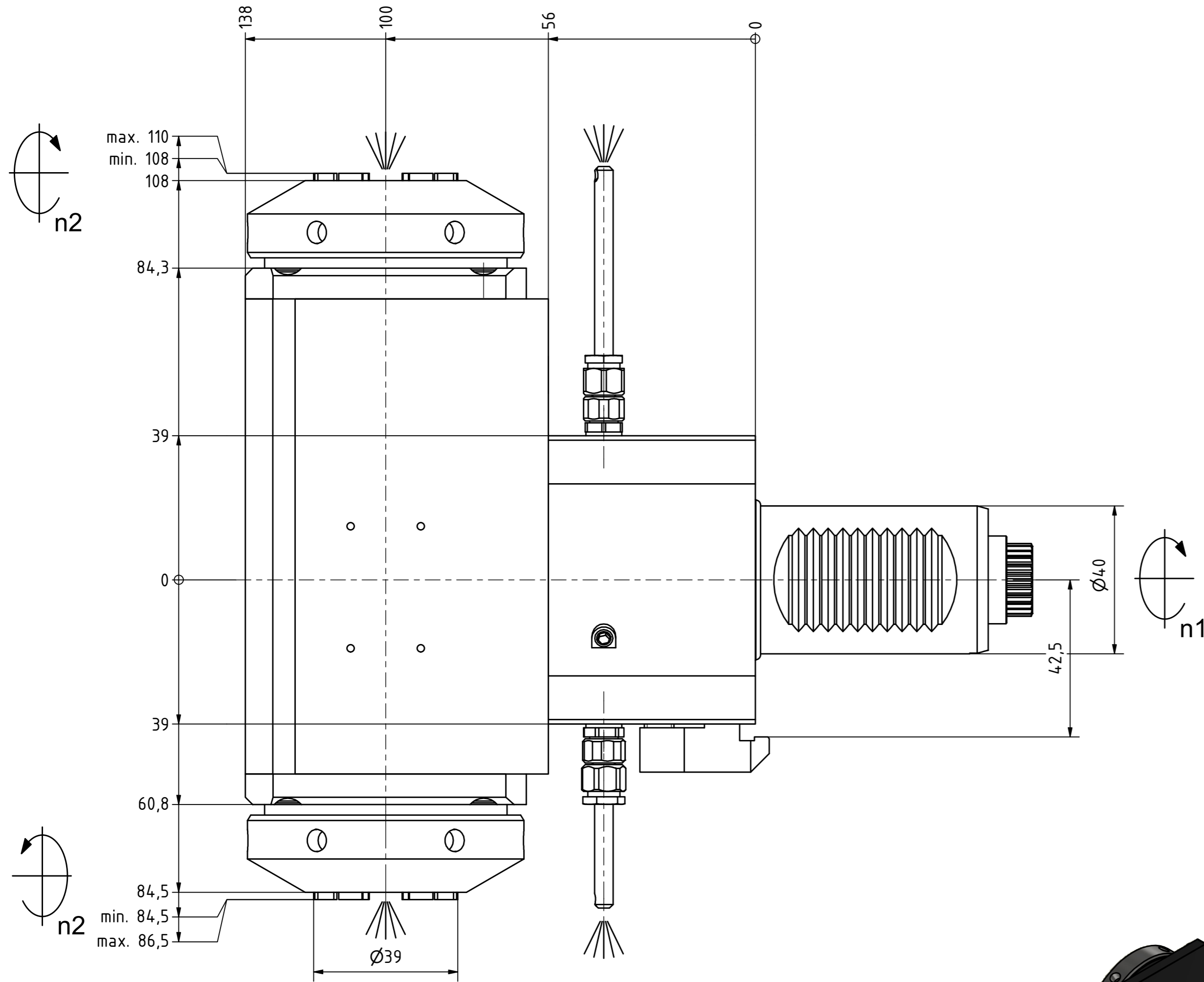

Spannzange / collet ER32 DIN6499
 Spannbereich / clamping range: 2,0 - 20,0

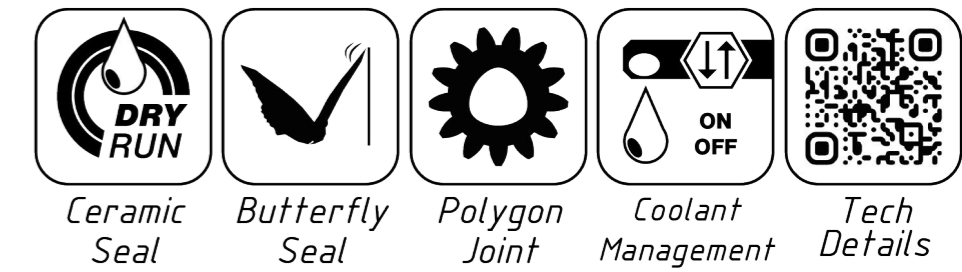
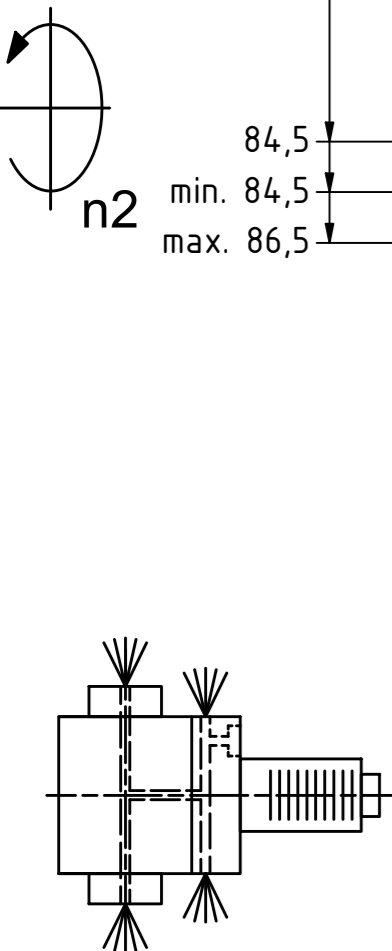
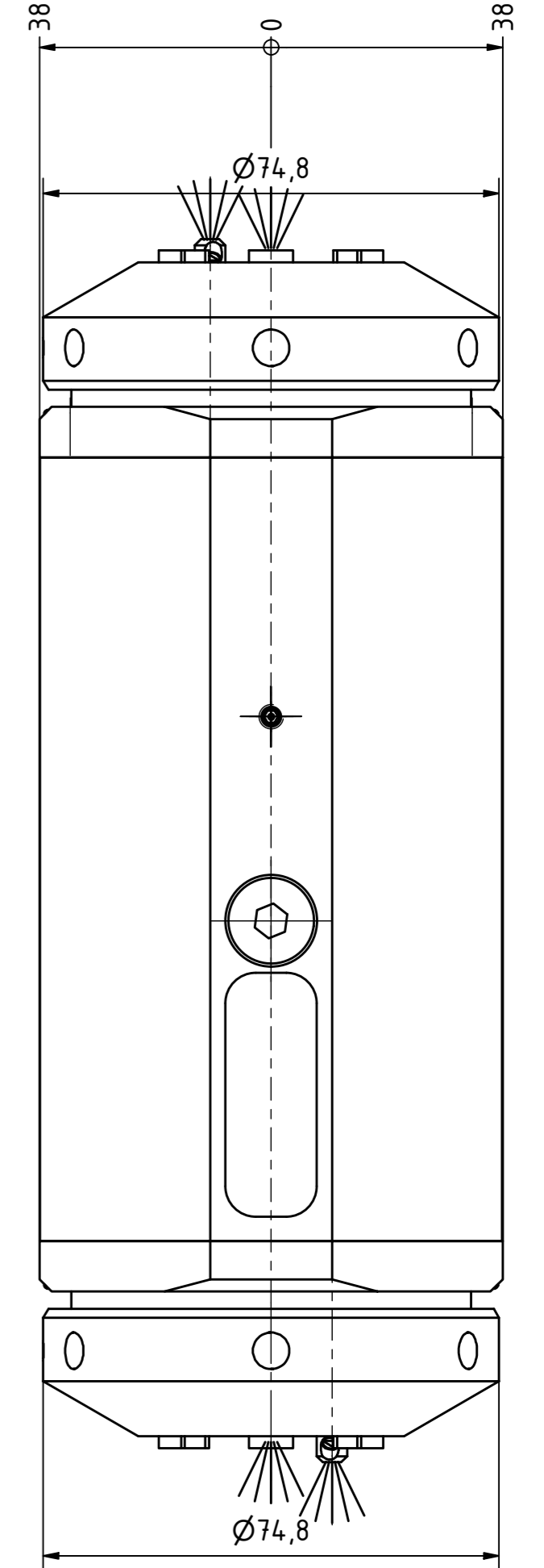

Innen- und Aussenkuehlung / Inside and outside coolant supply
 Kuehlmittelfiltrierung=50µ / coolant filtration=50µ

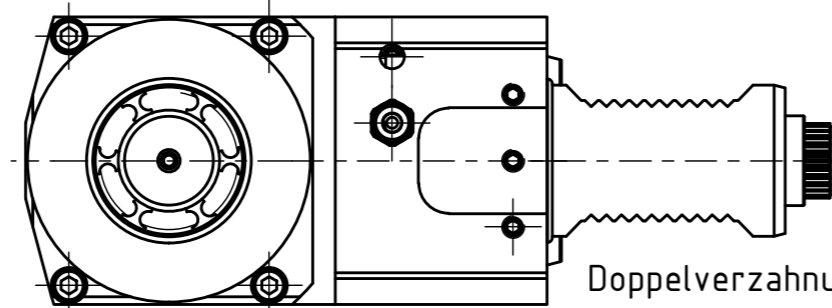

Doppelverzahnung Lizenz Traub
 double tooth system licence Traub

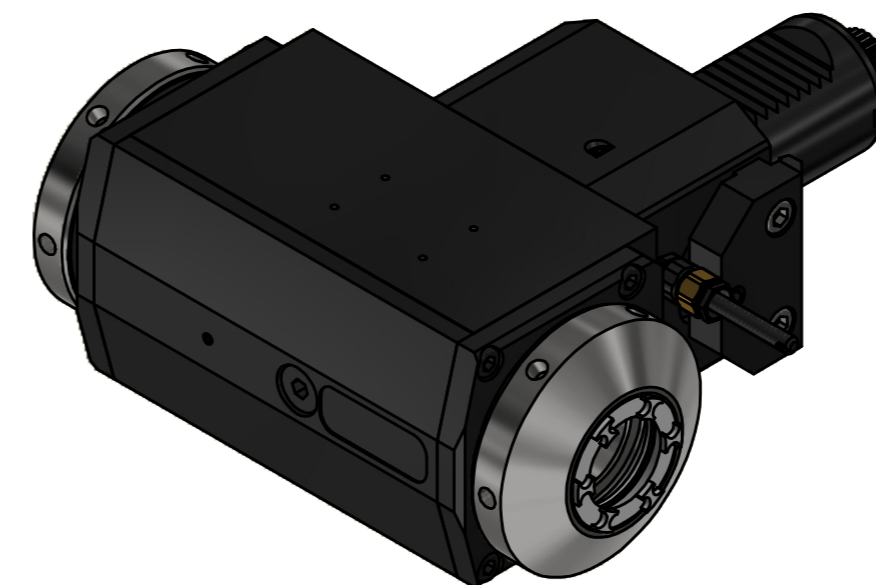

Spannzangenschlüssel für innenliegende Mutter
 Clamping wrench for internal collet
 232AX

Hakenschlüssel mit Zapfen
 Hook wrench with fixed pin
 DIN1810 B 68x75

Copyright EWS Tool Technologies
 Weitergabe und Vervielfaeltigung dieser Unterlage,
 Verwertung und Mitteilung ihres Inhalts nicht
 gestattet, soweit nicht ausdrecklich zugestanden.
 Zuwiderhandlungen verpflichten zu Schadenersatz.

Bemerkung - Note Für Trockenlauf geeignet! Use without coolant fluid allowed!	Technische Daten - technical data Weight = 9.562 [kg] Torque max. (M1/M2) = 63 / 63 63 [Nm] Speed max. (n1/n2) = 6000 / 6000 6000 [1/min] Gear ratio (i)=n1:n2 = 1:1 1:1 Pressure (pmax) = 70 [bar]
---	--

Benennung - Title
Radial Bohr und Fräskopf
Radial drilling and milling head

EWS Weigle GmbH & Co. KG Maybachstr. 1 D-73066 Ulm/ingen www.ews-tool.de	Technische Aenderungen vorbehalten! Subject to technical modifications! IDENT: DEWS260509	REV: -/A MNR.	
	Nr. - No. 60.4032DE365RLIKDIMX100	231736	