

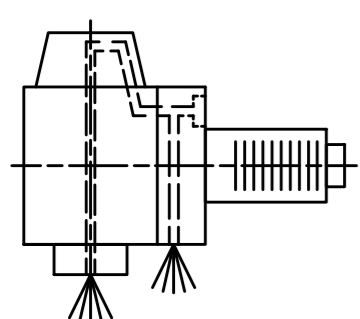

Ceramic Seal

Tech Details

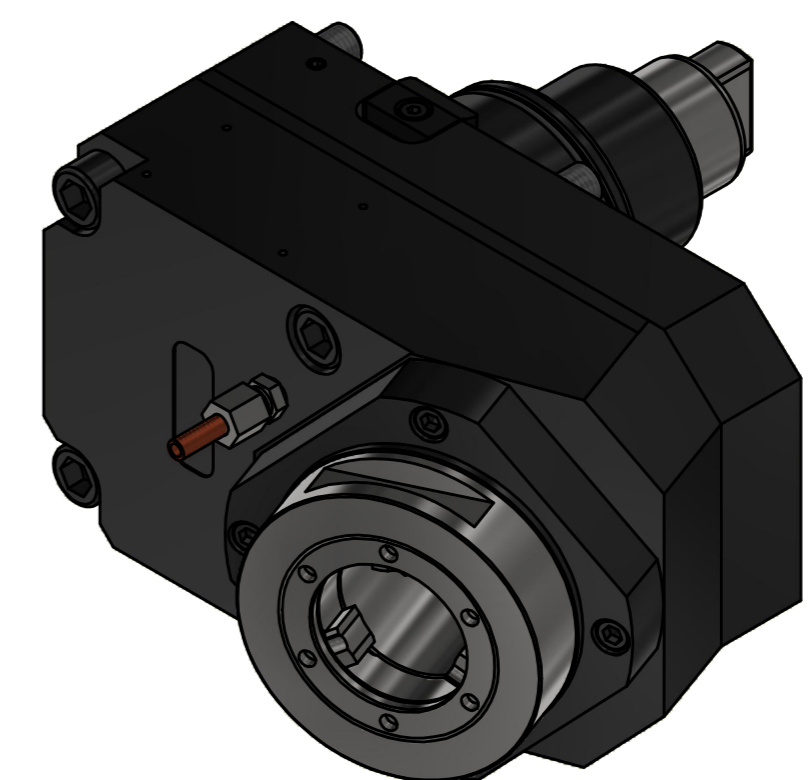
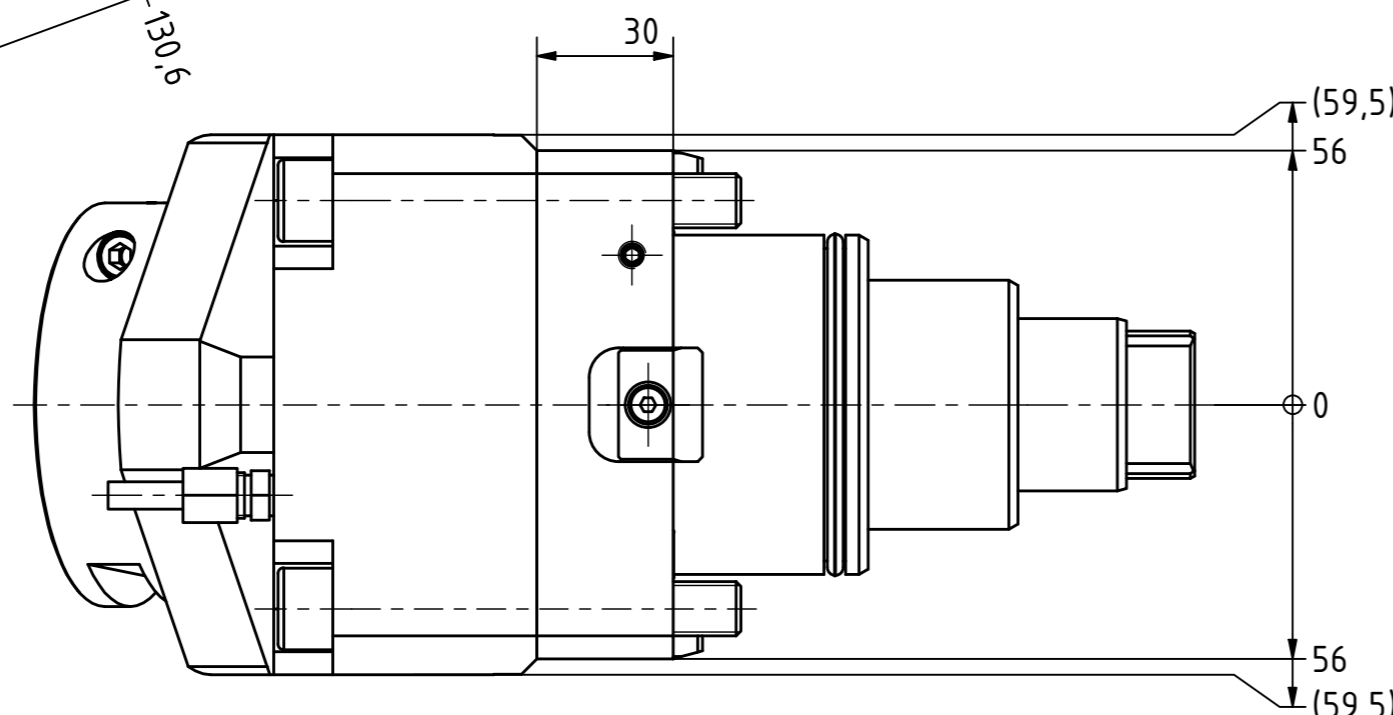
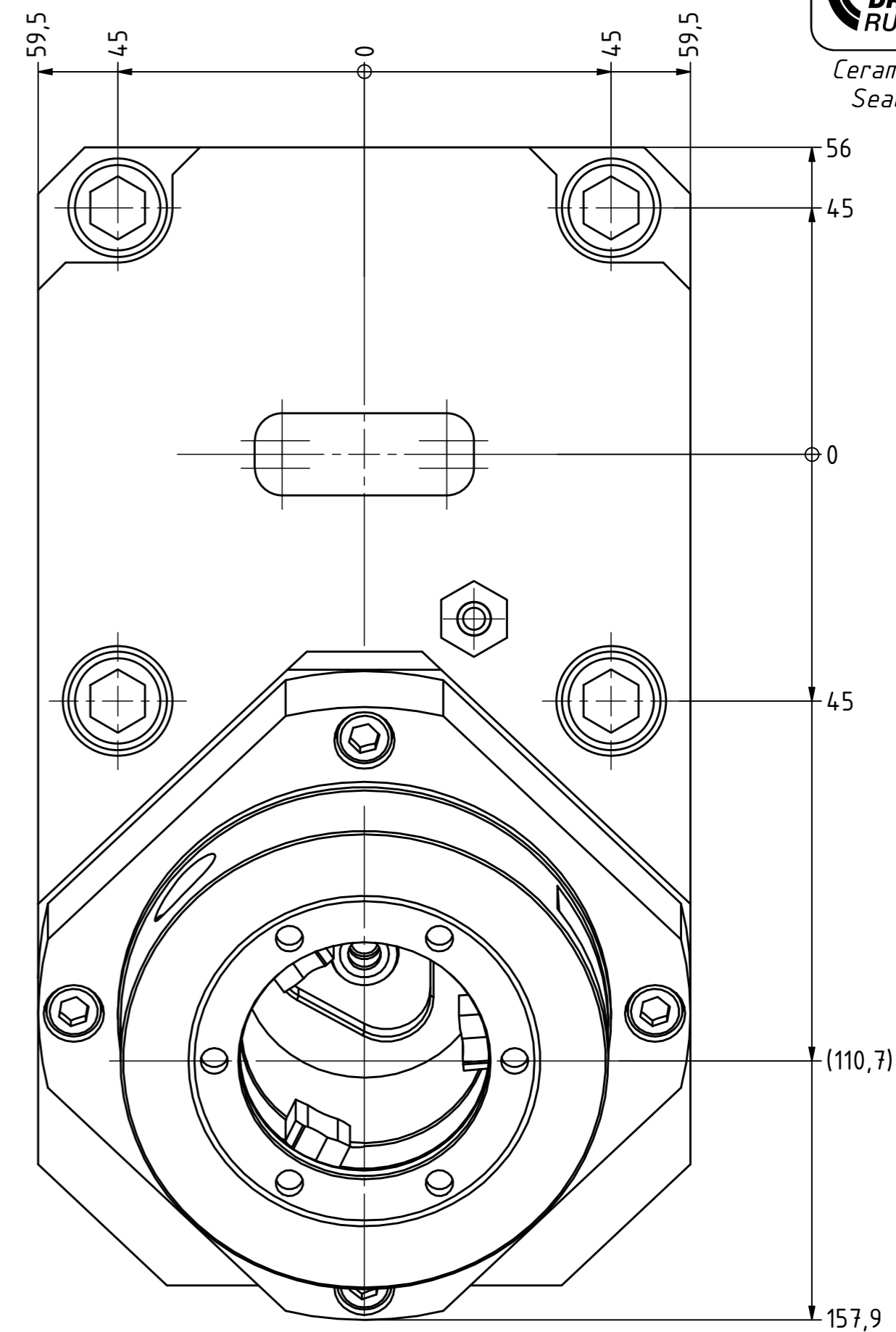
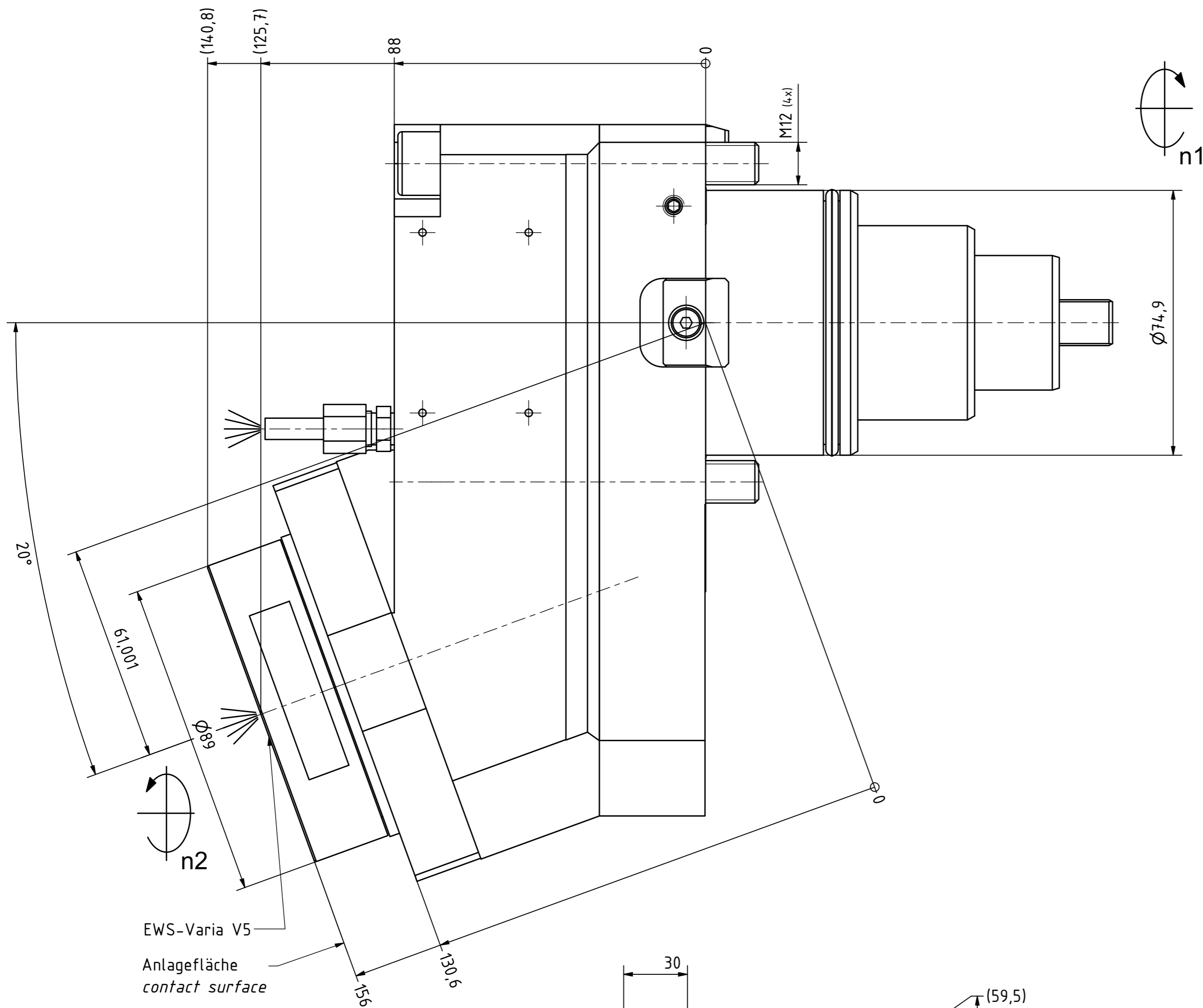

Innen- und Aussenkühlung / Inside and outside coolant supply
Kuehlmittelfiltrierung-50µ / coolant filtration-50µ

Bemerkung - Note
Für Trockenlauf geeignet!
Use without coolant fluid allowed!
mit Kegelrollenlager
with taper roller bearing(s)

Technische Daten - technical data
Weight = 17.126 [kg]
Torque max. (M1/M2) = 100 / 100 [Nm]
Speed max. (n1/n2) = 4000 / 4000 [1/min]
Gear ratio (i)=n1:n2 = 1:1
Pressure (pmax) = 70 [bar]

Benennung - Title
Radial Bohr und Fräskopf
Radial drilling and milling head

EWS Tool Technologies
EWS Weigle GmbH & Co. KG
Maybachstr. 1
D-73066 Ulm/ingen
www.ews-tool.de

Technische Aenderungen vorbehalten!
Subject to technical modifications!
IDENT: DEWS264812
REV: -/C
MNR.
231652



Copyright **EWS Tool Technologies**
Weitergabe und Vervielfaeltigung dieser Unterlage,
Verwertung und Mitteilung ihres Inhalts nicht
gestattet, soweit nicht ausdrecklich zugestanden.
Zuwoerhandlungen verpflichten zu Schadenersatz.