



EWS.Varia



Ceramic Seal



Tech Details

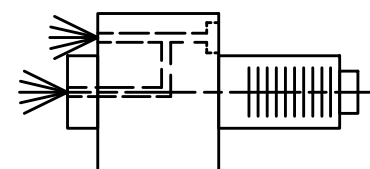
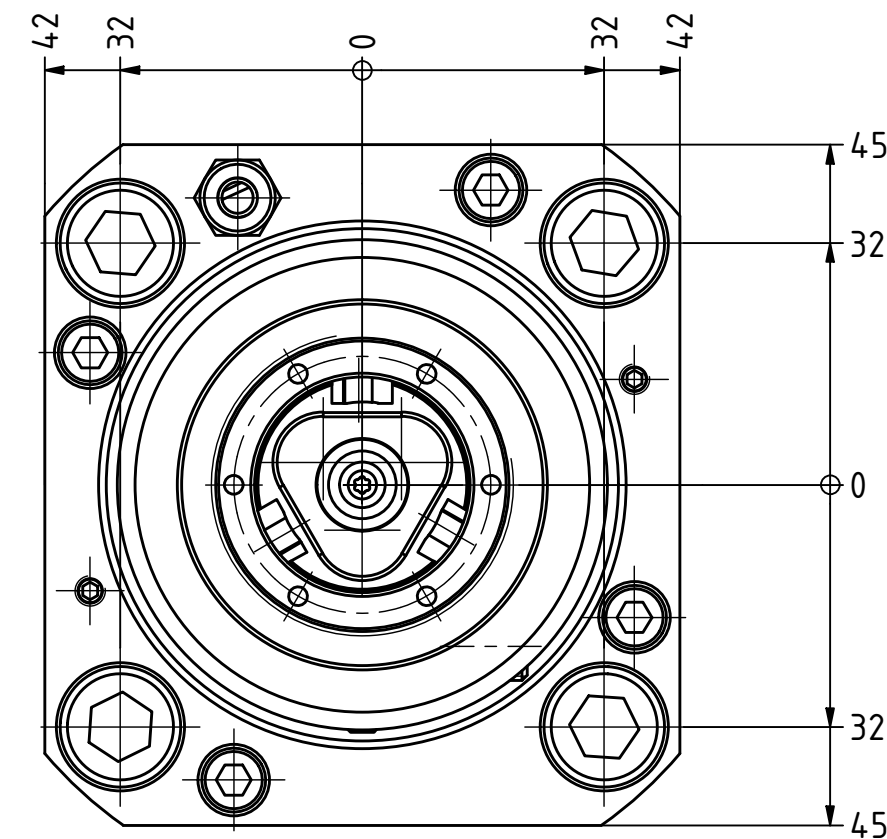
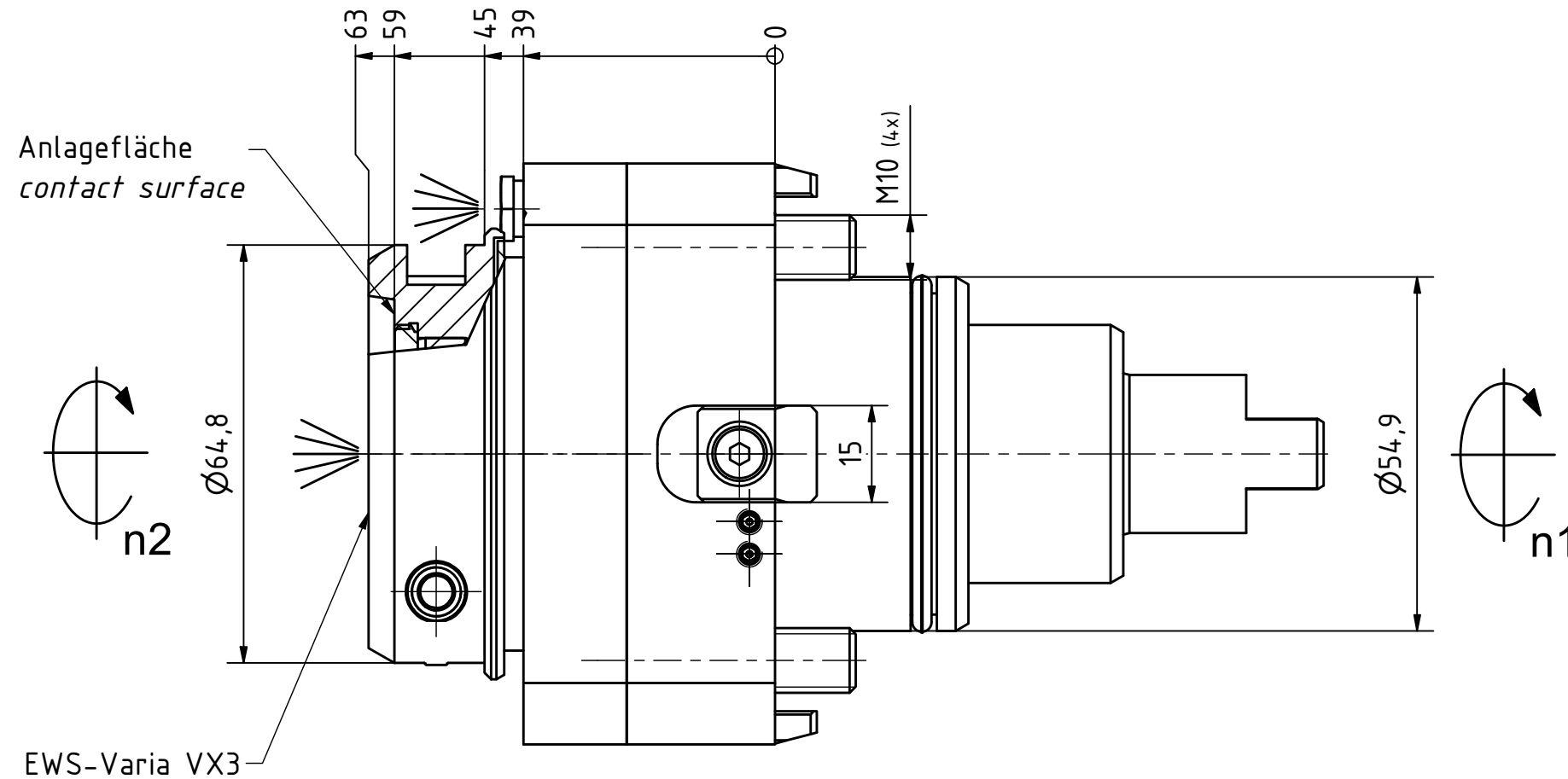

Innen- und Aussenkuehlung / Inside and outside coolant supply  
Kuehlmittelfiltrierung-50µ / coolant filtration-50µ

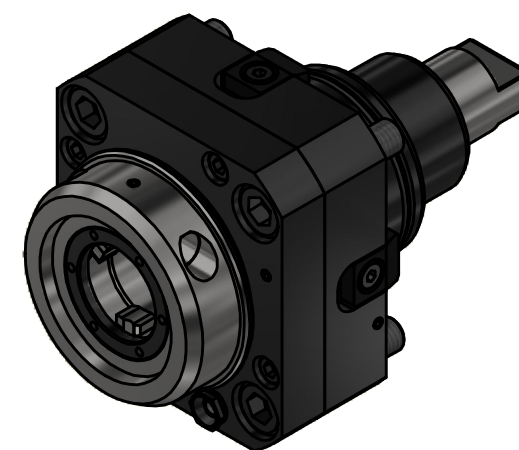

Copyright **EWS Tool Technologies**  
Weitergabe und Vervielfaeltigung dieser Unterlage,  
Verwertung und Mitteilung ihres Inhalts nicht  
gestattet, soweit nicht ausdrecklich zugestanden.  
Zuwiderhandlungen verpflichten zu Schadenersatz.

Bemerkung - Note

Für Trockenlauf geeignet!  
Use without coolant fluid allowed!  
mit Kegelrollenlager  
with taper roller bearing(s)

Technische Daten - technical data

Weight = 3.143 [kg]  
Torque max. (M1/M2) = 50 / 50 [Nm]  
Speed max. (n1/n2) = 5000 / 5000 [1/min]  
Gear ratio (i)=n1:n2 = 1:1  
Pressure (pmax) = 70 [bar]

Benennung - Title

**Axial Bohr und Fräskopf**  
**Axial drilling and milling head**



Nr. - No.

**40.55VX3KRVLHP2IKC**

EWS Weigle GmbH & Co. KG  
Maybachstr. 1  
D-73066 UHINGEN  
www.ews-tools.de

Technische Aenderungen vorbehalten!  
Subject to technical modifications!

IDENT: DEWS260284



REV: -/A

MNR.

**231707**

