

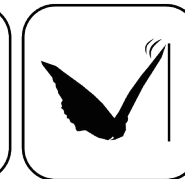

Ceramic Seal

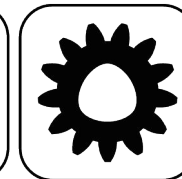

Butterfly Seal



Polygon Joint

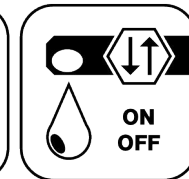

Coolant Management



Tech Details

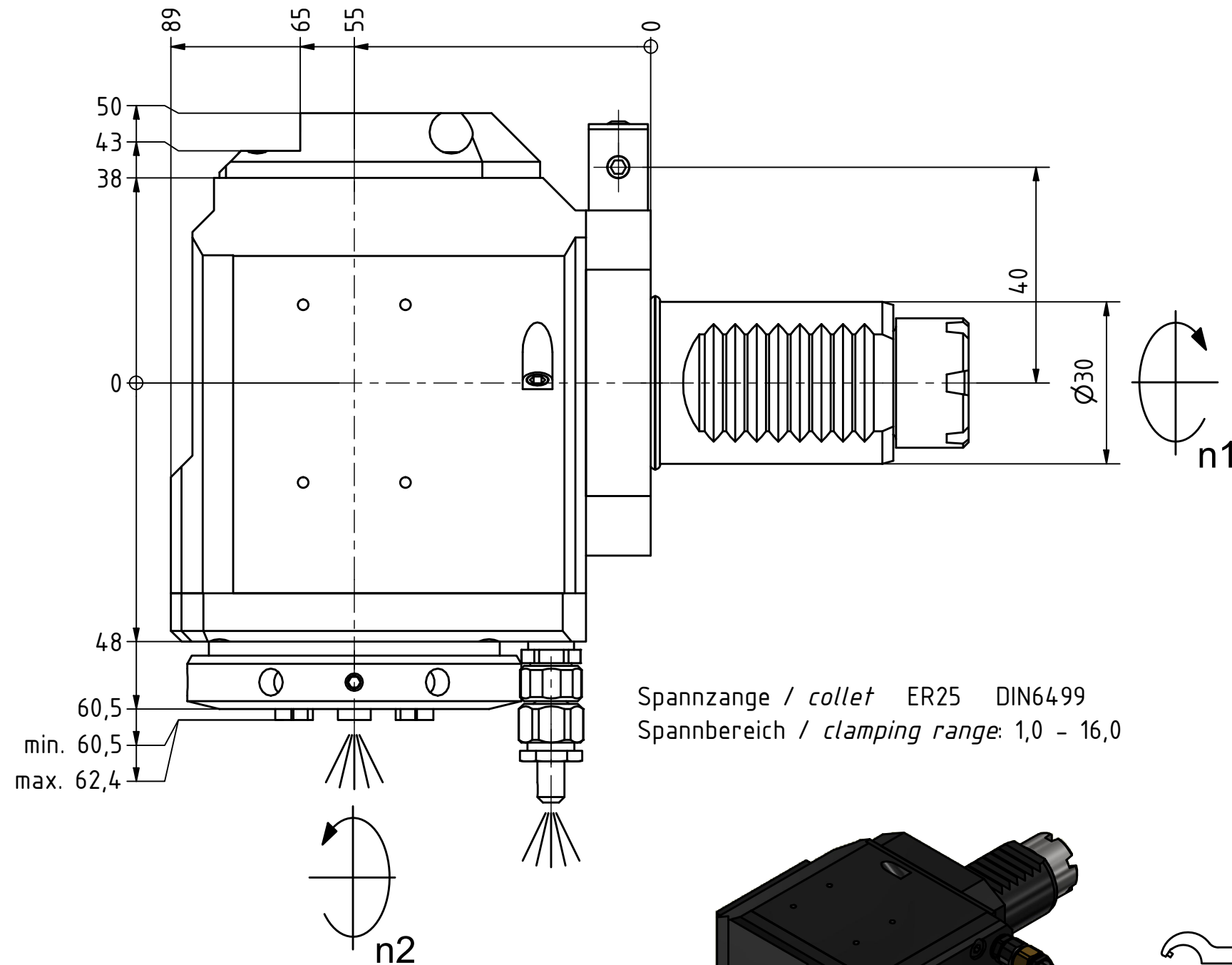

Spannzange / collet ER25 DIN6499
Spannbereich / clamping range: 1,0 - 16,0

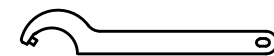
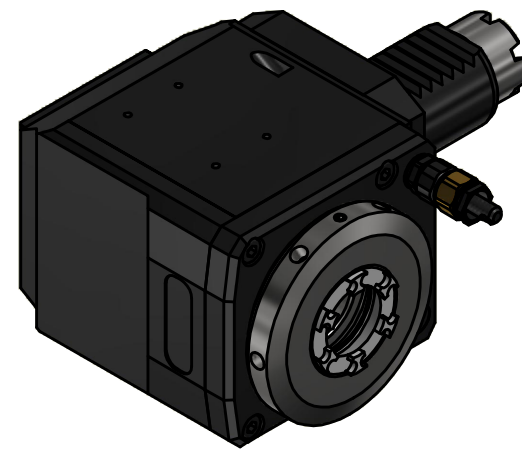

Hakenschlüssel
mit Zapfen
Hook wrench
with fixed pin
DIN1810 B 58x62

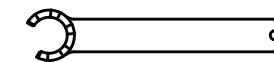

Spannzangenschlüssel für
innenliegende Mutter
Clamping wrench for
internal collet
225AX

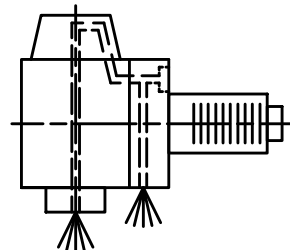

Innen- und Aussenkühlung / Inside and outside coolant supply
Kuehlmittelfiltrierung <math>< 50\mu</math> / coolant filtration <math>< 50\mu</math>

Copyright **EWS Tool Technologies**
Weitergabe und Vervielfaeltigung dieser Unterlage,
Verwertung und Mitteilung ihres Inhalts nicht
gestattet, soweit nicht ausdrecklich zugestanden.
Zuwiderhandlungen verpflichten zu Schadenersatz.

Bemerkung - Note
Für Trockenlauf geeignet!
Use without coolant fluid allowed!

Technische Daten - technical data	
Weight	= 3,585 [kg]
Torque max. (M1/M2)	= 32 / 32 [Nm]
Speed max. (n1/n2)	= 8000 / 8000 [1/min]
Gear ratio (i)=n1:n2	= 1:1
Pressure (pmax)	= 70 [bar]

Benennung - Title
Radial Bohr und Fräskopf
Radial drilling and milling head



Nr. - No.
60.3025TOEMRIKDIM

Technische Aenderungen vorbehalten!
Subject to technical modifications!
IDENT: DEWS259733

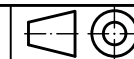

REV: -/A

MNR.
231619

