

Spannzangenschlüssel für
innenliegende Mutter
Clamping wrench for
internal collet
225AX

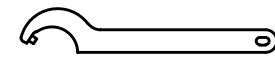

Hakenschlüssel
mit Zapfen
Hook wrench
with fixed pin
DIN1810 B 58x62



Ceramic
Seal

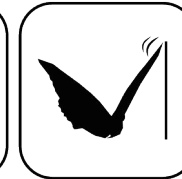

Butterfly
Seal

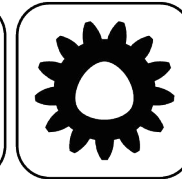

Polygon
Joint



Coolant
Management



Tech
Details

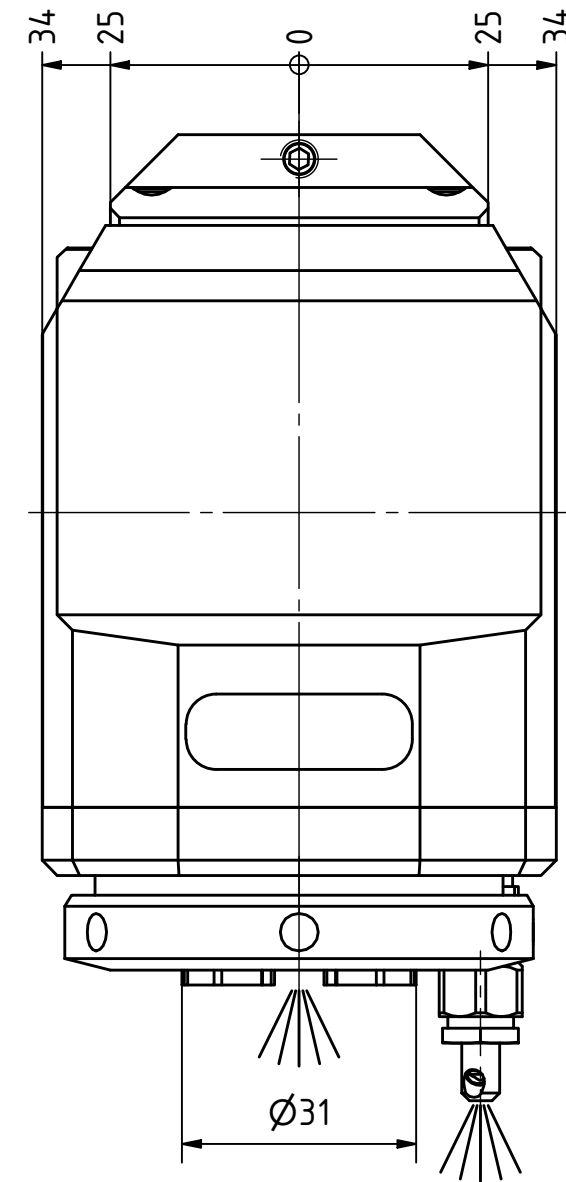
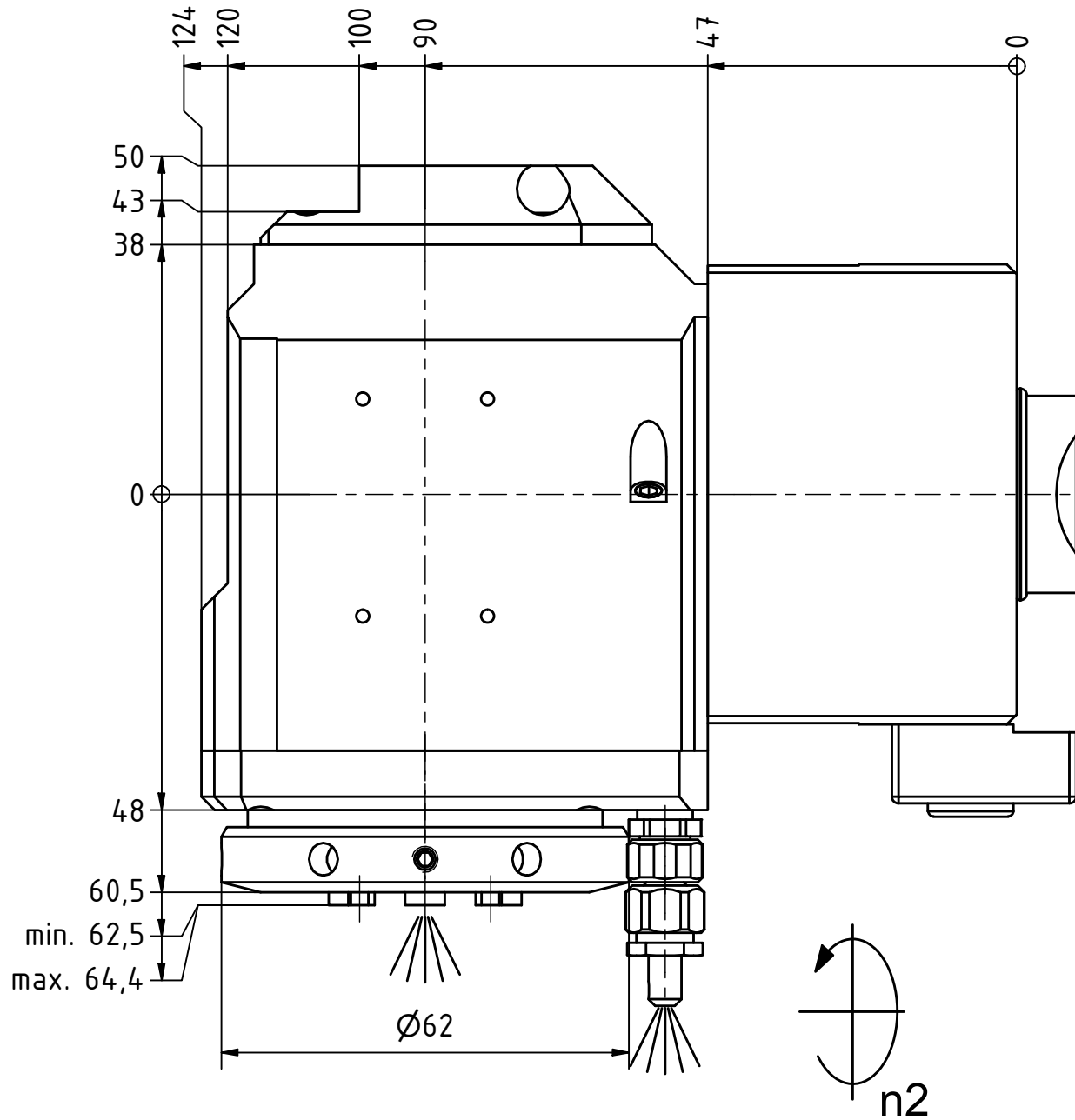

Spannzange / collet ER25 DIN6499
Spannbereich / clamping range: 1,0 - 16,0

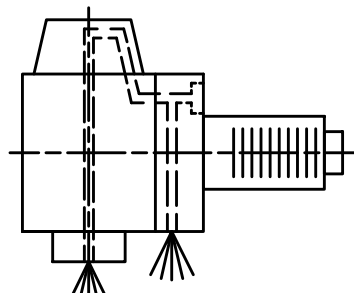
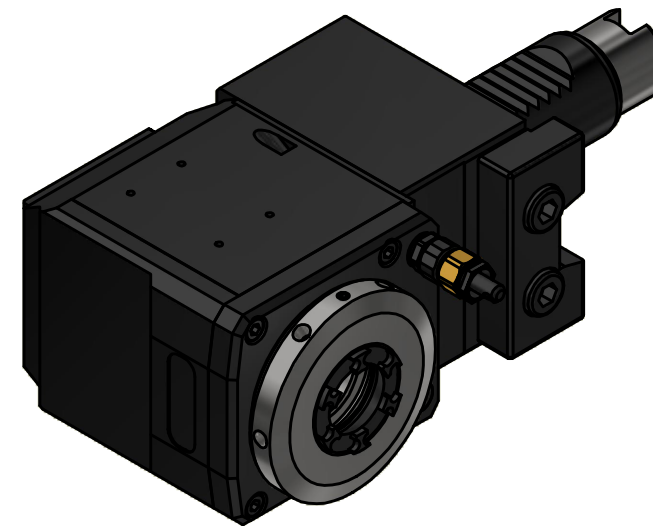

Innen- und Aussenkuehlung / Inside and outside coolant supply
Kuehlmittelfiltrierung 50μ / coolant filtration 50μ

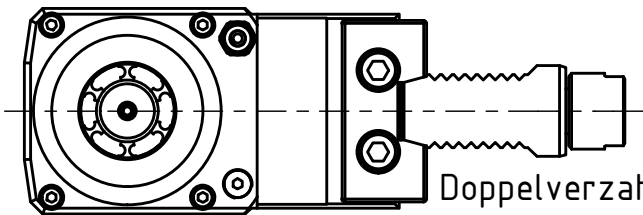

Doppelverzahnung Lizenz Traub
double tooth system licence Traub

Copyright **EWS Tool Technologies**
Weitergabe und Vervielfaeltigung dieser Unterlage,
Verwertung und Mitteilung ihres Inhalts nicht
gestattet, soweit nicht ausdrucklich zugestanden.
Zuwiderhandlungen verpflichten zu Schadenersatz.

Bemerkung - Note
Für Trockenlauf geeignet!
Use without coolant fluid allowed!
mit Kegelrollenlager
with taper roller bearing(s)

Technische Daten - technical data
Weight = 4.731 [kg]
Torque max. (M1/M2) = 32 / 32 [Nm]
Speed max. (n1/n2) = 5000 / 5000 [1/min]
Gear ratio (i)=n1:n2 = 1:1
Pressure (pmax) = 70 [bar]

Benennung - Title
Radial Bohr und Fräskopf
Radial drilling and milling head



Nr. - No.
60.3025KRG300RLIKDVIM

Technische Aenderungen vorbehalten!
Subject to technical modifications!
IDENT: DEWS259726

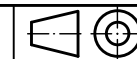

REV: -/A

MNR.

231609

