

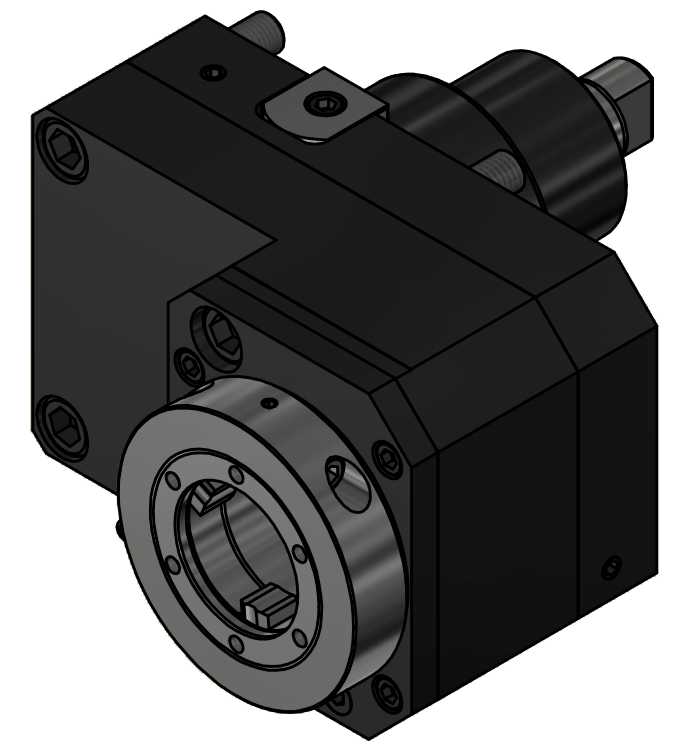

EWS-Varia V5



Copyright **EWS Tool Technologies**
 Weitergabe und Vervielfältigung dieser Unterlage,
 Verwertung und Mitteilung ihres Inhalts nicht
 gestattet, soweit nicht ausdrücklich zugestanden.
 Zuwiderhandlungen verpflichten zu Schadenersatz.

Bemerkung - Note	Technische Daten - technical data Weight = 12.416 [kg] Torque max. (M1/M2) = 80 / 40 [Nm] Speed max. (n1/n2) = 4000 / 8000 [1/min] Gear ratio (i)=n1:n2 = 1:2	Benennung - Title Axial Bohr u. Fräskopf achsversetzt Ax. drill. and mill. head offset	 EWS Weigle GmbH & Co. KG Maybachstr. 1 D-73066 Uhingen www.ews-tools.de Nr. - No. 50.75V5180911	Technische Änderungen vorbehalten! Subject to technical modifications! IDENT: DEWS260089 MNR. REV: -/A 231640	
------------------	---	--	---	---	---