

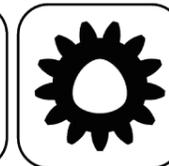

Ceramic Seal



Butterfly Seal



Polygon Joint

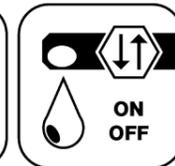

Coolant Management
ON
OFF



Tech Details

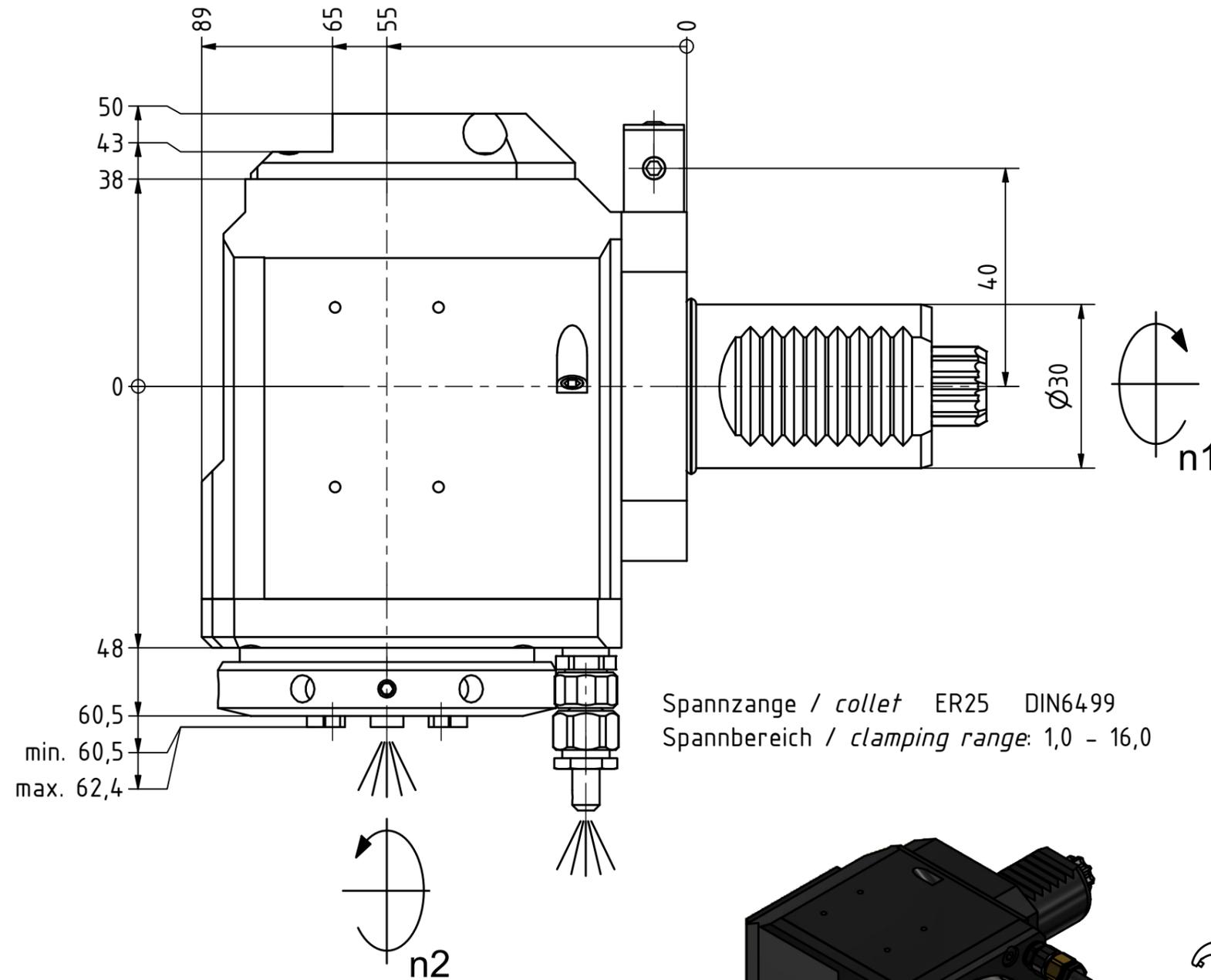

Spannzange / collet ER25 DIN6499
Spannbereich / clamping range: 1,0 - 16,0

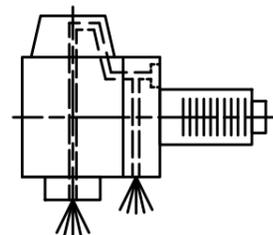
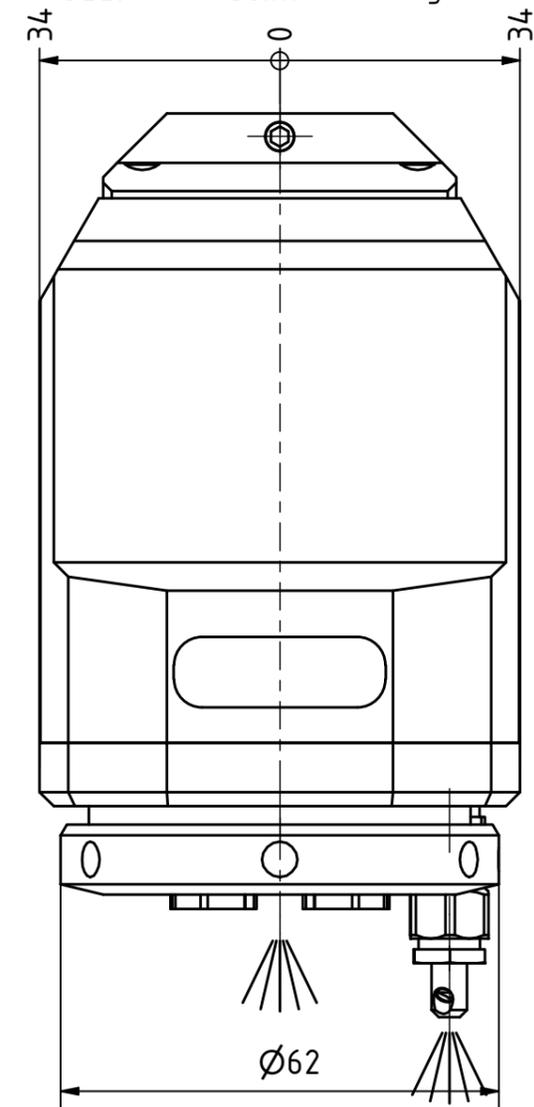

Innen- und Aussenkuehlung / Inside and outside coolant supply
Kuehlmittelfiltrierung 50μ / coolant filtration 50μ

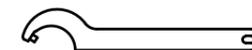
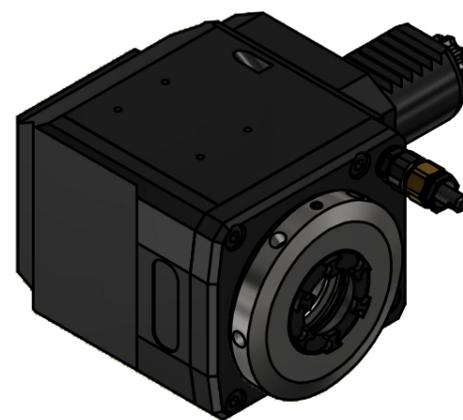

Hakenschlüssel
mit Zapfen
Hook wrench
with fixed pin
DIN1810 B 58x62

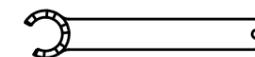

Spannzangenschlüssel für
innenliegende Mutter
Clamping wrench for
internal collet
225AX

Copyright **EWS Tool Technologies**
Weitergabe und Vervielfaeltigung dieser Unterlage,
Verwertung und Mitteilung ihres Inhalts nicht
gestattet, soweit nicht ausdrecklich zugestanden.
Zuwiderhandlungen verpflichten zu Schadenersatz.

Bemerkung - Note
Für Trockenlauf geeignet!
Use without coolant fluid allowed!

Technische Daten - technical data
Weight = 3,545 [kg]
Torque max. (M1/M2) = 32 / 32 [Nm]
Speed max. (n1/n2) = 8000 / 8000 [1/min]
Gear ratio (i)=n1:n2 = 1,963:1
Pressure (pmax) = 70 [bar]

Benennung - Title
Radial Bohr und Fräskopf
Radial drilling and milling head



Nr. - No.
60.30255482RIKDIM#01

Technische Aenderungen vorbehalten!
Subject to technical modifications!
IDENT: DEWS259766



REV: -/A

MNR.
231625

