

Spannzangenschlüssel für innenliegende Mutter
Clamping wrench for internal collet
225AX

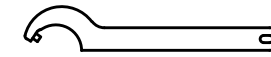

Hakenschlüssel mit Zapfen
Hook wrench with fixed pin
DIN1810 B 58x62



Butterfly Seal

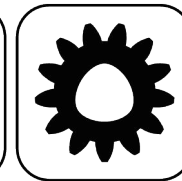

Polygon Joint

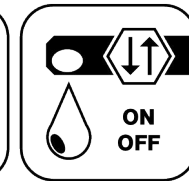

Coolant Management

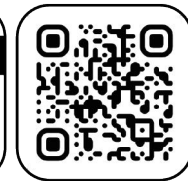

Tech Details

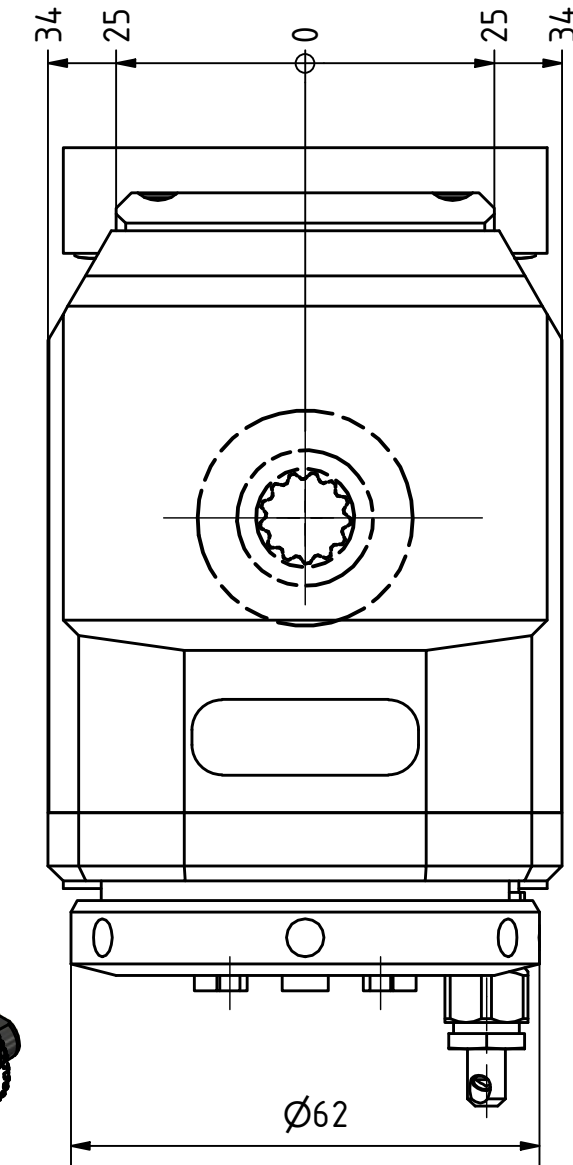
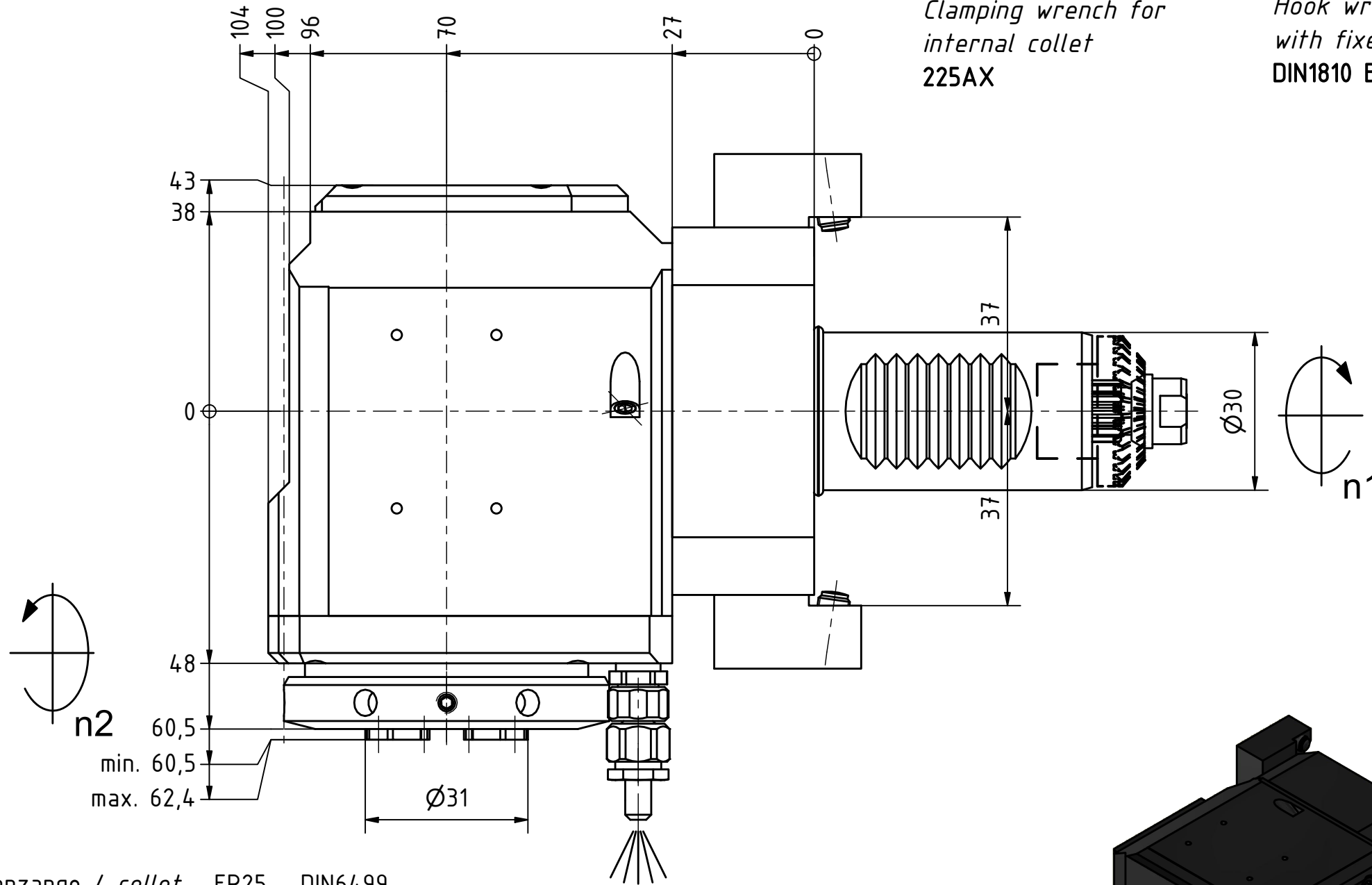

Spannzange / collet ER25 DIN6499
Spannbereich / clamping range: 1,0 - 16,0

Gewindebohrzange / tapping collet
ET-1-25 M3-M12

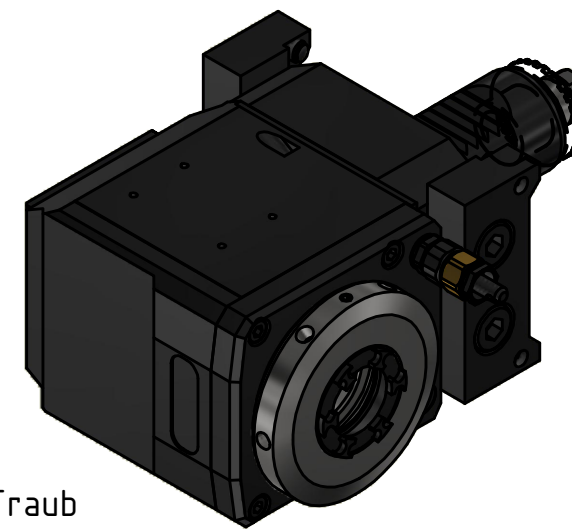
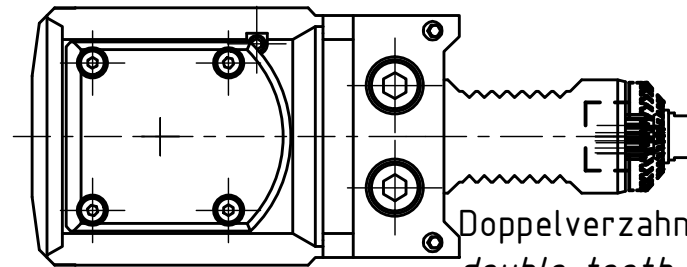

Copyright **EWS Tool Technologies**
Weitergabe und Vervielfältigung dieser Unterlage,
Verwertung und Mitteilung ihres Inhalts nicht
gestattet, soweit nicht ausdrücklich zugestanden.
Zuwendungen verpflichten zu Schadenersatz.

Bemerkung - Note
mit Kegelrollenlager
with taper roller bearing(s)

Technische Daten - technical data
Weight = 4.181 [kg]
Torque max. (M1/M2) = 32 / 32 [Nm]
Speed max. (n1/n2) = 5000 / 5000 [1/min]
Gear ratio (i)=n1:n2 = 1:1

Benennung - Title
Radial Bohr und Fräskopf
Radial drilling and milling head

EWS Tool Technologies
EWS Weigle GmbH & Co. KG
Maybachstr. 1
D-73066 Utingen
www.ews-tools.de

Technische Änderungen vorbehalten!
Subject to technical modifications!
IDENT: DEWS259497
REV: -/A
MNR.
231579

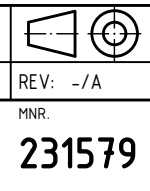

QR